

Moulded Case Circuit Breaker

NXM series moulded case circuit breaker	P-001
--	-------

Overview	P-003
-----------------	-------

Product selection	P-009
--------------------------	-------

Code of inner accessories	P-017
----------------------------------	-------

Functions and features	P-027
Technical parameters	P-035
Protection feature	P-045
Accessories	P-058
Complementary technical data	P-058

Dimensions and installation	P-062
------------------------------------	-------

Tripping curves	P-081
------------------------	-------

Accessories

- 1 Body
- 2 Alarm contact (optional)
- 3 Motor-driven mechanism (optional)
- 4 Auxiliary contact (optional)
- 5 Connection plate (optional)
- 6 Shunt release (optional)
- 7 Rear connection plate (optional)
- 8 Under voltage release (optional)
- 9 Interphase barrier (standard)
- 10 Plug-in basement(optional)
- 11 Handheld test module(optional)
- 12 Manual operation mechanism (optional)



Product installation size and weight

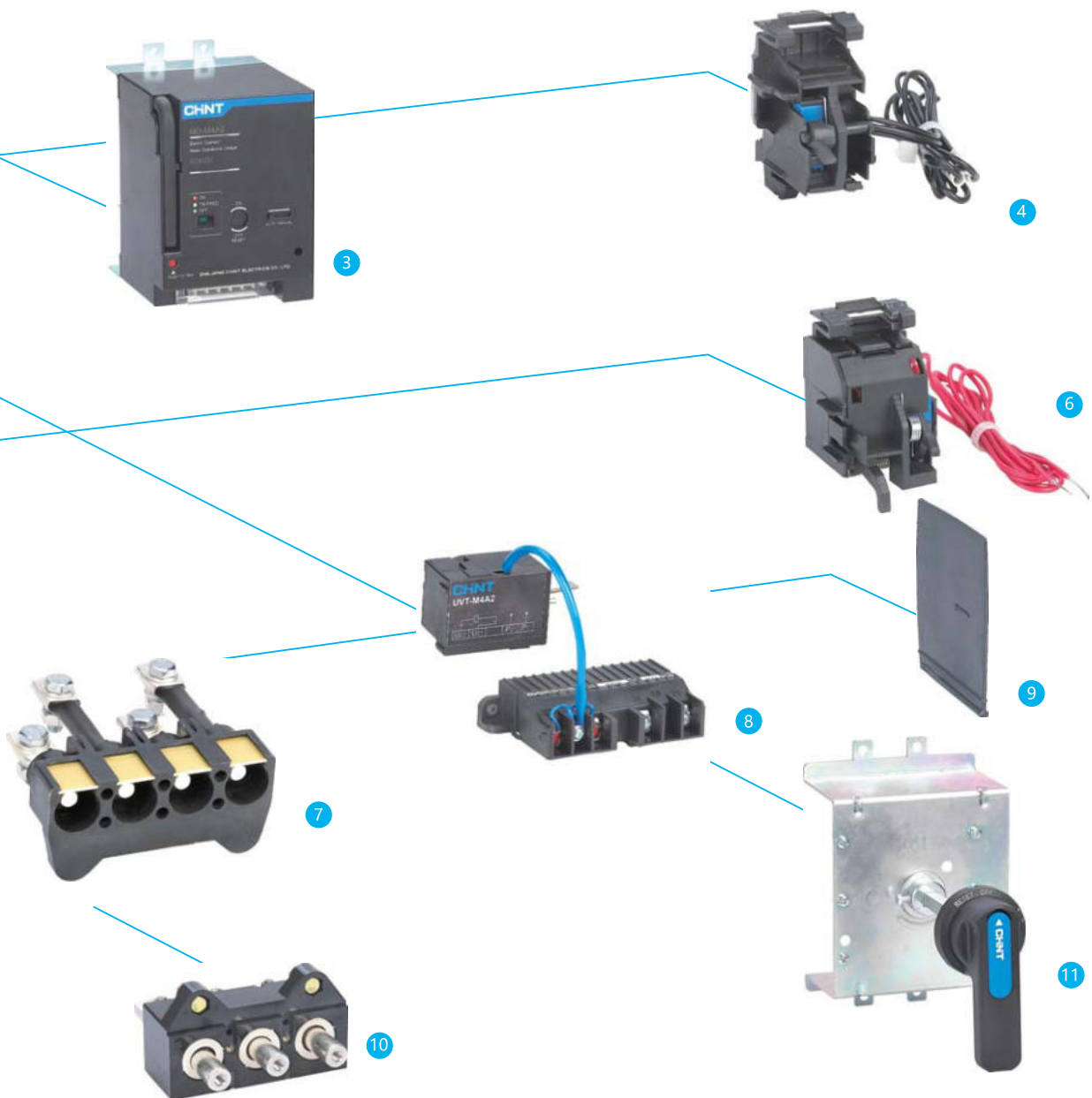



NXM-250S/4300A



NXMS-250H/3300

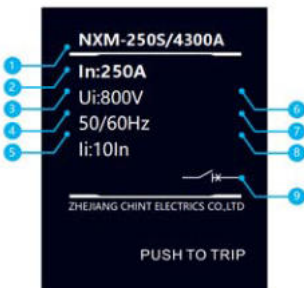

NXM Nameplate of thermomagnetic stationary molded case circuit breaker

NXM series moulded case circuit breaker

Breaker

The moulded case circuit breaker will provide protection for the circuit and equipment in case of overload, short circuit and under voltage condition occurred in the power distribution circuit. Besides, it can also provide protection of overload, short circuit and under voltage for the non-frequent start of motor

- Frame size:
NXMS series moulded case circuit breaker: 63A, 125A, 160A, 250A, 400A, 630A, 800A, 1000A, 1250A, 1600A
NXM series moulded case circuit breaker
- Rated operational voltage: U_e : 220V/230V/240V, 380V/400V/415V, 500V , 690V
- Breaking capacity code: E, S, F, H
- Number of poles: 2P, 3P, 4P
- Release type: thermal magnetic fixed type; magnetic fixed type; electronic type.
- Installation method: Fixed type; plug-in type

Nameplate interpretation

- 1 Product type: Frame size; breaking capacity; poles number
- 2 In: Rated operational current
- 3 Ui: Rated insulation voltage
- 4 Frequency of A.C.
- 5 li: 10In Multiple of current of transient behavior
- 6 Uimp: Rated impulsive withstand voltage
- 7 Cat A: Utilization category of breaker
- 8 +40°C : Ambient temperature
- 9 Electrical symbol for circuit breaker with isolating function
- 10 U_e : Rated operational voltage
- 11 The product is in conformity with standard IEC/EN 60947.2
- 12 Icu/Ics: Ultimate short circuit breaking capacity/Service short circuit breaking capacity

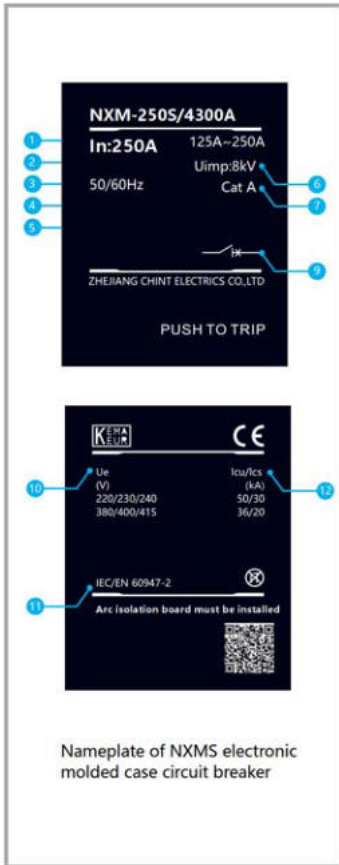

- ① Product type: Frame size; breaking capacity; poles number
- ② In: Rated operational current
- ③ IR: Long-time-delay setting current range
- ④ Ui: Rated insulation voltage
- ⑤ Frequency of A.C.
- ⑥ Uimp: Rated impulsive withstand voltage
- ⑦ Cat A: Utilization category of breaker
- ⑧ Electrical symbol for circuit breaker with isolating function
- ⑨ Ue: Rated operational voltage
- ⑩ The product is in conformity with standard IEC/EN 60947.2
- ⑪ Icu/Ics: Ultimate short circuit breaking capacity/Service short circuit breaking capacity

Electronic release

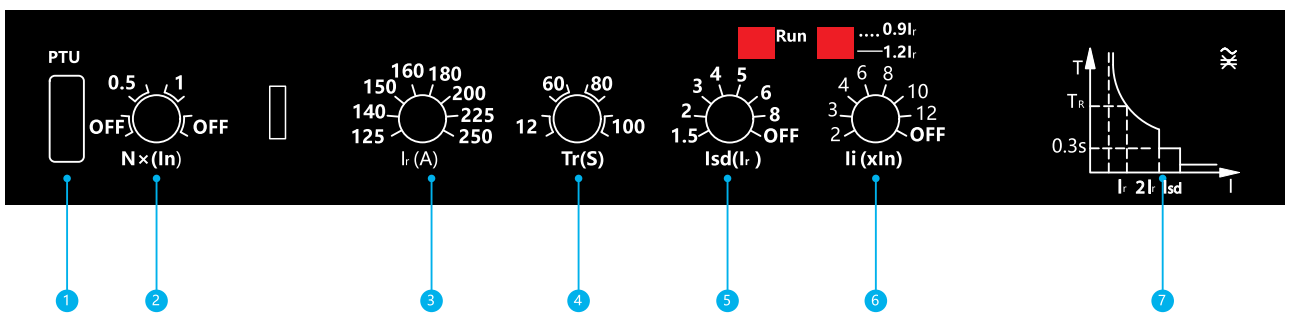

- ① PTU interface
- ② Neutral pole protection current setting, with 2 steps of current that is adjustable and can be turned off (OFF)
- ③ Rated current setting with 8 steps
- ④ Long-time-delay (s) setting with 4 steps
- ⑤ Short-time-delay current Istd setting with 7 steps that is adjustable and can be turned off (OFF)
- ⑥ Instantaneous action current Ii setting with 7 steps and that can be turned off (OFF)
- ⑦ Current-time protection curve



NXMLE-250S/4300A

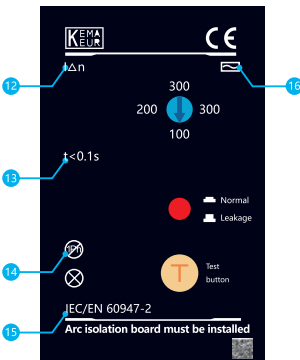
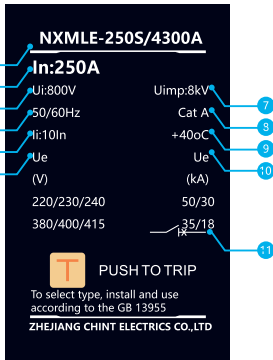

Nameplate of NXMLE residual current circuit breaker

NXMLE series residual current circuit breaker

Residual current operated protection breaker (Coming soon)

Residual current circuit breakers are used mainly to provide protection against leakage current which may cause insulation failure, electric shock to equipment and human body irrespectively along with the standard protection against over load & short circuit condition.

- Frame size: 125A, 160A, 250A, 400A, 630A
- Rated operational voltage: U_e (V AC): 220/230/240,(1P+N,2P) 380/400/415(3P,3P+N,4P)
- Breaking capacity code: S, F, H
- Number of poles: 1PN, 2P, 3P, 3PN, 4P
- Installation method: fixed type; plug-in type

Nameplate interpretation

- 1 Product type: Frame size; breaking capacity; poles number
- 2 In: Rated operational current
- 3 U_i : Rated insulation voltage
- 4 Frequency of A.C.
- 5 I_i : 10In Multiple of current of transient behavior
- 6 U_e : Rated operational voltage
- 7 U_{imp} : Rated impulsive withstand voltage
- 8 Cat A: Utilization category of breaker
- 9 +40°C : Ambient temperature
- 10 I_{cu}/I_{cs} : Rated ultimate breaking capacity / Rated service breaking capacity
- 11 Electrical symbol for circuit breaker with isolating function
- 12 Rated residual operating current value
- 13 t: Maximum breaking time
- 14 Only applicable for three-phase power
- 15 The product is in conformity with standard IEC/EN 60947.2
- 16 Leakage current selection (mA)



NXHM series disconnector switch

Disconnecter switch (Coming soon)

The disconnecter switch series are mainly used for non-frequent circuit making or breaking circuit in the distribution network.

- Frame size: 63A, 125A, 160A, 250A, 320A, 400A, 630A, 800A, 1000A
- Rated operational voltage: U_e (VAC): 380/400/415/690
- Number of poles: 3P, 4P
- Installation method: fixed type; plug-in type



NXHM-250

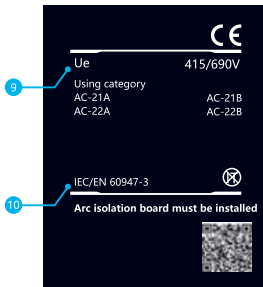
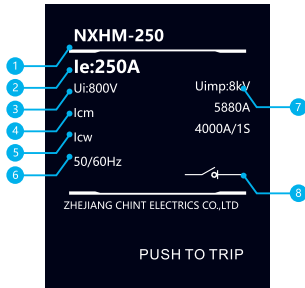

Nameplate of NXHM disconnector switch

Installation method: stationary type and plug-in type

- 1 Product type: Frame size; poles number
- 2 Ie: Rated operational current
- 3 U_i : Rated insulation voltage
- 4 I_{cm} : Rated short-time making capacity
- 5 I_{cw} : Rated short-time withstand current
- 6 Frequency of A.C.
- 7 U_{imp} : Rated impulsive withstand voltage
- 8 Disconnecter Function as per IEC/EN
- 9 U_e : Rated operational voltage
- 10 The product is in conformity with standard IEC/EN 60947.3

Compliant with standard



- Product standard
 - IEC 60947-1(General rules)
 - IEC 60947-2(Breaker)
 - IEC 60947-3(switch, disconnecter)
 - IEC 60947-4(motor, drive)
- Use standard in extreme environment
 - IEC 60068-2-1(low temperature)
 - IEC 60068-2-2(dry heat)
 - IEC 60068-2-11(salt mist)
 - IEC 60068-2-30(damp and hot)

Anti-humid heat capacity



The product has passed the environmental test of dry cold, dry heat, and wet heat and the like. It can operate reliably under extreme environmental conditions.



Environment temperature



It must calculate according to the temperature compensation coefficient table provided in the sample in the event the temperature is lower than -5°C or higher than 40°C .

Altitude and pollution degree



The installation altitude of normal operation is 2000 m and below. In case of higher than 2000m, it must consider the decrease of dielectric strength and colder air. The amendment action shall be implemented according to the altitude derating factor table provided in the sample.

The product can operate reliably in pollution degree III environment defined in IEC 60947-1 and 60664-1 (industrial environment).

Protection grade



The product is in conformity with the standard requirements of IEC 60529 (enclosure protection grade).

Product body: protection grade is IP30 (except the wiring terminal position)

NXM series moulded case circuit breaker

Model definition and description

NXM	160	S	P	4	300
Product code	Frame size code	Breaking capacity code ²⁾	Operation way code	Number of poles code	Code of release type and inner accessories ³⁾
NXM: moulded case circuit breaker	63A 125A 160A 250A 400A 630A 800A 1000A 1250A 1600A	E: 15kA S: 25kA F: 36kA H: 50kA E: 20kA S: 36kA F: 36kA H: 50kA E: 36kA S: 50kA F: 50kA H: 70kA S: 50kA F: 50kA H: 70kA S: 50kA H: 70kA	No code: direct handle operation P: motor operation Z: rotary handle operation	2: 2 poles 3: 3 poles 4: 4 poles	First number represents the release type 2: only magnetic type 3: thermal magnetic type The second number and the third number are codes of inner accessories

Model selection examples:

NXM-160SP/4300 2 A G 100 R: To order one moulded case circuit breaker with 160A frame size, 35kA breaking capacity, thermal adjustable and magnetic fixed release, with motor-driven mechanism, 4 poles, with no inner accessories, motor protection, the category of four poles is A, with overload alarm non-tripping function. The rated current is 100A and rear connection.

Note: 1) The rated current of each frame can be seen in table 1.

2) The corresponding poles number and breaking capacity related to frame size can be seen in table 2.

3) For tripping method and inner accessories, see page 17-20.

Comparison table of frame sizes and rated current

Rated current (A)	10	15	16	20	25	30	32	40	50	60	63	65	70	75	80	90	100	110	125	140	150	160	
63	■	■	■	■	■	■	■	■	■	■	■												
125		■	■	■	■	■	■	■	■	■	■	■	■	■	■	■	■	■	■				
160					■	■	■	■	■	■	■		■	■	■		■	■	■	■	■	■	■
250																							■
400																							
630																							
800																							
1000																							
1250																							
1600																							

Comparison table of frame sizes, number of poles and breaking capacity

Frame size (A)	63	125	160	250					
Number of poles	2P	3P	4P	2P	3P	4P	2P	3P	4P
E	■	■	■	■	■	■	■	■	■
S	■	■	■	■	■	■	■	■	■
F	-	■	■	-	■	■	-	■	■
H	-	■	■	-	■	■	-	■	■

	300	2	T	125	Other
	Releasing method and code of inner accessories	Usage code	Communication module code	Rated current ¹⁾	Code of installation or secondary voltage
	<p>First number represents the release type.</p> <p>3: The second number and the third number are code of inner accessories</p>	<p>No code: distribution protection</p> <p>2: motor protection</p>	<p>No code: no communication module</p> <p>T: with communication module</p>	<p>32A~1600A</p>	<p>No code: front connection</p> <p>R: rear connection</p> <p>DR: plug-in type of rear connection</p>

NXMLE series residual current circuit breaker

Description

NXMLE	125	H	P	/	3	300	2
Product code	Frame size code	Breaking capacity code ²⁾	Code of operation mode		Code of poles number	Releasing method and code of inner accessories ³⁾	Usage code
NXMLE: residual current circuit breaker	125A	S: 25kA F: 18kA H: 36kA	No code: direct handle operation P: motor operation Z: rotary handle operation		1PN 2P 3P 3PN 4P	First number represents the release type. only magnetic type 2: type6) 3: thermal magnetic type The second number and the third number are codes of accessories	No code distribution protection 2: motor protection
	160A						
	250A	S: 35kA H: 50kA					
	400A						
	630A	S: 50kA H: 75kA					

Model selection examples:

NXMLE-125H P/4300 2 A 100 J A Y R: To order one residual current circuit breaker with 125A frame size, 35kA breaking capacity, with motor-driven mechanism, 3 poles, thermal magnetic fixed type release, with no inner accessories, motor protection, the code of N pole is A.

The rated current is 100A with electric leakage alarm non-trip function, and the residual current value is A (30/50/100). It is delay type and rear connection.

Rated current (A)	10	16	20	25	32	40	50	63	80	100	125	160	180
Frame size (A)	125	■	■	■	■	■	■	■	■	■	■		
	160										■	■	
	250											■	■
	400												■
	630												

Comparison table of frame size, poles number and breaking capacity

Frame size (A)	125			160			250		
Number of poles	1PN/2P	3P	3PN/4P	1PN/2P	3P	3PN/4P	1PN/2P	3P	3PN/4P
Code of breaking capacity	S	■	■	■	■	■	■	■	■
	F	-	■	■	-	■	■	-	■
	H	-	■	■	-	■	■	-	■

Comparison table of frame size and residual current value and code

Frame size (A)	125			160			250		
Fixed single grade, non-delay type	30/50/100/200/300/500			30/50/100/200/300/500			30/50/100/200/300/500		
Adjustable 3 grades, non-delay type	A: 30/50/100			A: 30/50/100			A: 30/50/100		
	B: 50/100/200			B: 50/100/200			B: 50/100/200		
	C: 100/200/300			C: 100/200/300			C: 100/200/300		
	D: 200/300/500			D: 200/300/500			D: 200/300/500		
Fixed single grade, delay type	50/100/200/300/500			50/100/200/300/500			50/100/200/300/500		
Adjustable 3 grades, delay type	B: 50/100/200			B: 50/100/200			B: 50/100/200		
	C: 100/200/300			C: 100/200/300			C: 100/200/300		
	D: 200/300/500			D: 200/300/500			D: 200/300/500		
	-			-			-		

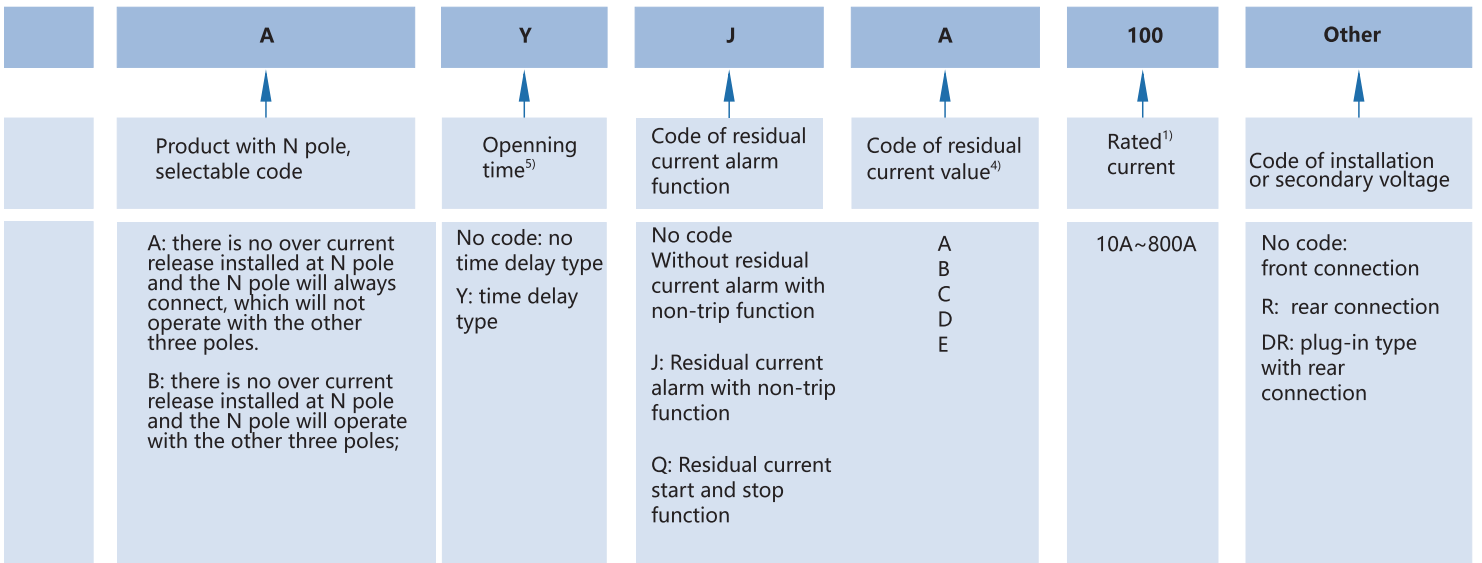

Note: ¹⁾ See table 5 for rated current included in each frame size
²⁾ See table 6 for corresponding poles, breaking capacity.
³⁾ See page 23-24 for release type and inner accessories.

⁴⁾ As for the un-adjustable type, mark the residual current value directly; for the adjustable type, mark the code.
⁵⁾ See table 8 for opening time.

Table 5

	200	225	250	315	350	400	500	630
	■	■	■	■	■	■	■	■
			■	■	■	■		
			■	■	■	■	■	■

Table 6

	400			630	
	3P	3PN/4P	3PN/4P	3P	3PN/4P
	■	■	■	■	■
	■	■	■	■	■
	■	■	■	■	■

Table 7

	400	630
	50/100/200/300/500/1000	50/100/200/300/500/1000
	B: 50/100/200	B: 50/100/200
	C: 100/200/300	C: 100/200/300
	D: 200/300/500	D: 200/300/500
	E: 300/500/1000	E: 300/500/1000
	50/100/200/300/500/1000	50/100/200/300/500/1000
	B: 50/100/200	B: 50/100/200
	C: 100/200/300	C: 100/200/300
	D: 200/300/500	D: 200/300/500
	E: 300/500/1000	E: 300/500/1000

Comparison table of frame size and maximum opening time

Frame size (A)	125	160	250
Non-delay type (s)	≤ 0.1	≤ 0.1	≤ 0.1
Delay type Y (s)	0.3/0.4/0.5	0.3/0.4/0.5	0.3/0.4/0.5

NXHM series switch disconnecter

Description

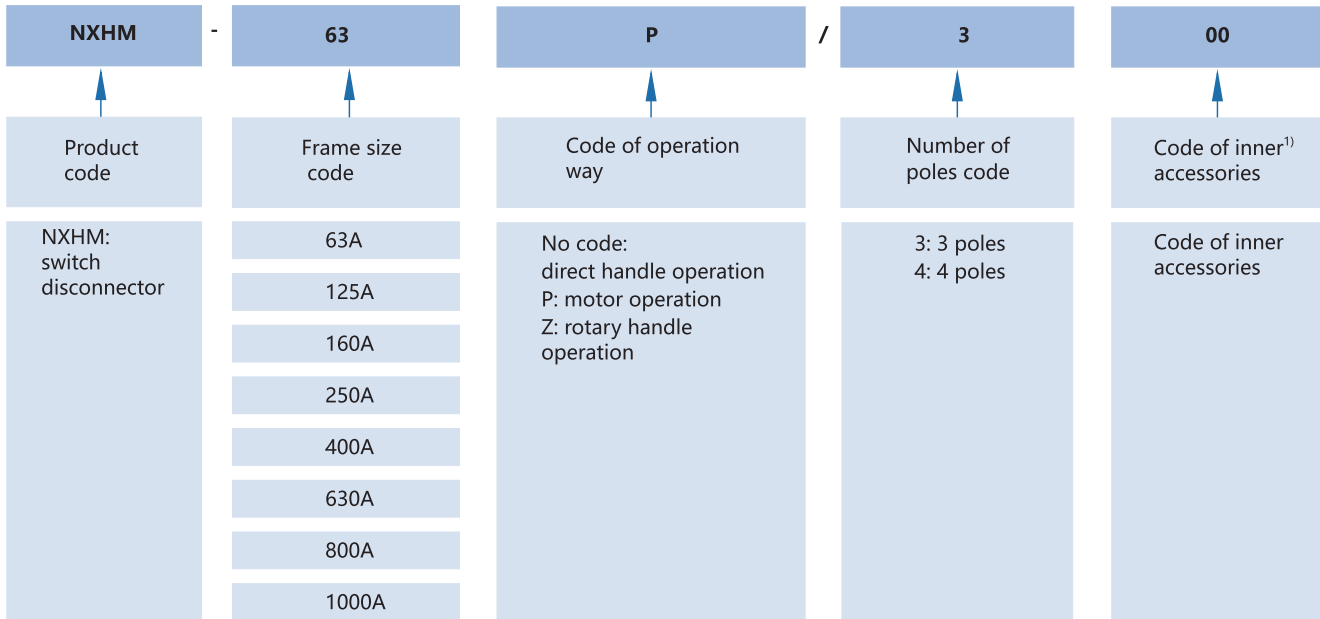

Model selection examples:

NXHM-63 P/300 : To order one disconnecter switch with 63A frame size, with motor-driven mechanism, 3 poles, with no inner accessories rear connection.

Note: 1) See page 25-26 of product sample for inner accessories code. The number code "00" can be omitted in case of no inner accessories.

Table 8

	400	630
	≤ 0.1	≤ 0.1
	0.3/0.4/0.5	0.3/0.4/0.5



NXM series moulded case circuit breaker, code of inner accessories

□ Alarm contact, ■ Auxiliary contact, ● Shunt release, ○ Under voltage release.

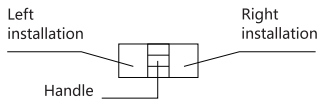

Accessories name	Accessories code		NXM-63E/S NXM-125E/S		NXM-63F/H NXM-125F/H	
	Only magnetic	Thermal magnetic release	3P	4P	3P	4P
No inner accessories	200	300				
Alarm contact	208	308	□	□	□	□
Shunt release	210	310	●	●	●	●
● Auxiliary contact (1NO1NC)	220	320	■	■	■	■
Auxiliary contact (2NO2NC)						
Under voltage release	230	330	○	○	○	○
Shunt release, auxiliary contact (1NO1NC)	240	340	● ■	● ■	● ■	● ■
Shunt release, auxiliary contact (2NO2NC)						
Under voltage release, shunt release	250	350	○ ●	○ ●	○ ●	○ ●
Two groups of auxiliary contact (2NO2NC)	260	360				
Under voltage release, auxiliary contact (1NO1NC)	270	370	○ ■	○ ■	○ ■	○ ■
Under voltage release, auxiliary contact (2NO2NC)						
Shunt release, alarm contact	218	318	● □	● □	● □	● □
Auxiliary contact (1NO1NC), alarm contact	228	328	■ □	■ □	■ □	■ □
Auxiliary contact (2NO2NC), alarm contact						
Under voltage release, alarm contact	238	338	○ □	○ □	○ □	○ □
Shunt release, auxiliary contact (1NO1NC), alarm contact	248	348	● ■ □	● ■ □	● ■ □	● ■ □
Two groups of auxiliary contact (2NO2NC), alarm contact	268	368				
Under voltage release, auxiliary contact (1NO1NC), alarm contact	278	378	○ ■ □	○ ■ □	○ ■ □	○ ■ □



	NXM-160E/S		NXM-160F/H	
	3P	4P	3P	4P

(Continued from the table above)

Accessories name	Accessories code		NXM-250E/S		NXM-250F/H	
	Only magnetic	Thermal magnetic release	3P	4P	3P	4P
No inner accessories	200	300				
Alarm contact	208	308				
Shunt release	210	310				
Auxiliary contact (1NO1NC)	220	320				
Auxiliary contact (2NO2NC)						
Under voltage release	230	330				
Shunt release, auxiliary contact (1NO1NC)	240	340				
Shunt release, auxiliary contact (2NO2NC)						
Under voltage release, shunt release	250	350				
Two groups of auxiliary contact (2NO2NC)	260	360				
Under voltage release, auxiliary contact (1NO1NC)	270	370				
Under voltage release, auxiliary contact (2NO2NC)						
Shunt release, alarm contact	218	318				
Auxiliary contact (1NO1NC), alarm contact	228	328				
Auxiliary contact (2NO2NC), alarm contact						
Under voltage release, alarm contact	238	338				
Shunt release, auxiliary contact (1NO1NC), alarm contact	248	348				
Two groups of auxiliary contact (2NO2NC), alarm contact	268	368				
Under voltage release, auxiliary contact (1NO1NC), alarm contact	278	378				



NXM-400E/S/F/H NXM-630E/S/F/H		NXM-800S/F/H NXM-1000S/H		NXM-1250S/H		NXM-1600S/H	
3P	4P	3P	4P	3P	4P	3P	4P

NXMS series electronic moulded case circuit breaker, code of inner accessories

Accessories name	Accessories code		NXMS-160F/H		NXMS-250F/H	
	Only magnetic	Thermal magnetic release	3P	4P	3P	4P
No inner accessories	200	300				
Alarm contact	208	308				
Shunt release	210	310				
Auxiliary contact (1NO1NC)	220	320				
Auxiliary contact (2NO2NC)						
Under voltage release	230	330				
Shunt release, auxiliary contact (1NO1NC)	240	340				
Shunt release, auxiliary contact (2NO2NC)						
Under voltage release, shunt release	250	350				
Two groups of auxiliary contact (2NO2NC)	260	360				
Under voltage release, auxiliary contact (1NO1NC)	270	370				
Under voltage release, auxiliary contact (2NO2NC)						
Shunt release, alarm contact	218	318				
Auxiliary contact (1NO1NC), alarm contact	228	328				
Auxiliary contact (2NO2NC), alarm contact						
Under voltage release, alarm contact	238	338				
Shunt release, auxiliary contact (1NO1NC), alarm contact	248	348				
Two groups of auxiliary contact (2NO2NC), alarm contact	268	368				
Under voltage release, auxiliary contact (1NO1NC), alarm contact	278	378				



NXMS-400S/F/H NXMS-630S/F/H		NXMS-1000S/H		NXMS-1250S/H		NXMS-1600S/H	
3P	4P	3P	4P	3P	4P	3P	4P

NXMLE series residual current circuit breaker, code of inner accessories

Accessories name	Accessories code		NXMLE-125S/H		NXMLE-160S/F/H	
	Only magnetic	Thermal magnetic release	3P	3PN/4P	3P	3PN/4P
No inner accessories	200	300				
Alarm contact	208	308				
Shunt release	210	310				
Auxiliary contact (1NO1NC)	220	320				
Auxiliary contact (2NO2NC)						
Under voltage release	230	330				
Shunt release, auxiliary contact (1NO1NC)	240	340				
Shunt release, auxiliary contact (2NO2NC)						
Under voltage release, shunt release	250	350				
Two groups of auxiliary contact (2NO2NC)	260	360				
Under voltage release, auxiliary contact (1NO1NC)	270	370				
Under voltage release, auxiliary contact (2NO2NC)						
Shunt release, alarm contact	218	318				
Auxiliary contact (1NO1NC), alarm contact	228	328				
Auxiliary contact (2NO2NC), alarm contact						
Under voltage release, alarm contact	238	338				
Shunt release, auxiliary contact (1NO1NC), alarm contact	248	348				
Two groups of auxiliary contact (2NO2NC), alarm contact	268	368				
Under voltage release, auxiliary contact (1NO1NC), alarm contact	278	378				



NXMLE-250S/F/H		NXMLE-400S/F/H NXMLE-630S/F/H		
3P	3PN/4P	3P	3PN/4P	

NXHM series disconnecter switch, code of inner accessories

Accessories name	Accessories code	NXHM-63 NXHM-125		NXHM-160	
		3P	4P	3P	4P
No inner accessories	00				
Alarm contact	08				
Shunt release	10				
Auxiliary contact (1NO1NC)	20				
Auxiliary contact (2NO2NC)					
Under voltage release	30				
Shunt release, auxiliary contact (1NO1NC)	40				
Shunt release, auxiliary contact (2NO2NC)					
Under voltage release, shunt release	50				
Two groups of auxiliary contact (2NO2NC)	60				
Under voltage release, auxiliary contact (1NO1NC)	70				
Under voltage release, auxiliary contact (2NO2NC)					
Shunt release, alarm contact	18				
Auxiliary contact (1NO1NC), alarm contact	28				
Auxiliary contact (2NO2NC), alarm contact					
Under voltage release, alarm contact	38				
Shunt release, auxiliary contact (1NO1NC), alarm contact	48				
Two groups of auxiliary contact (2NO2NC), alarm contact	68				
Under voltage release, auxiliary contact (1NO1NC), alarm contact	78				



	NXHM-250 NXHM-320		NXHM-400 NXHM-630		NXHM-800		NXHM-1000	
	3P	4P	3P	4P	3P	4P	3P	4P

Technical Parameters

NXM series moulded case circuit breaker

Frame Size, rated current Inm (A)		63				125				160				250				
Rated current In (A), 40°C , 55°C		10,16,20,25,30,32,40,50,60,63				10,16,20,25,30,32,40,50,60,63,70,75,80,100,125				32,40,50,60,63,70,75,80,100,125,140,150,160				160,170,180,200,225,250				
Rated insulation voltage Ui(V)		800				800				800				800				
Rated impulse withstand voltage Uimp(kV)		8				8				8				8				
Rated operational voltage Ue(V), ACS0/60Hz		220/230/240, 380/400/415/500				220/230/240, 380/400/415/500				220/230/240, 380/400/415				220/230/240, 380/400/415				
Breaking capacity code		E	S	F	H	E	S	F	H	E	S	F	H	E	S	F	H	
Number of poles	2P	■	■	-	-	■	■	-	-	■	■	-	-	■	■	-	-	
	3P	■	■	■	■	■	■	■	■	■	■	■	■	■	■	■	■	
	4P	■	■	■	■	■	■	■	■	■	■	■	■	■	■	■	■	
Rated ultimate short circuit breaking capacity Icu (kA)	AC220/230/240V	18	36	50	75	18	36	50	75	40	50	50	75	40	50	50	75	
	AC380/400/415V	15	25	36	50	15	25	36	50	20	36	36	50	20	36	36	50	
	AC500V	-	-	15	25	-	-	-	-	-	-	-	-	-	-	-	-	
Rated service short circuit breaking capacity Ics (kA)	AC220/230/240V	18	18	50	50	18	18	50	50	30	30	50	50	30	30	50	50	
	AC380/400/415V	15	15	36	36	15	15	36	36	20	20	36	36	20	20	36	36	
	AC500V	-	-	15	25	-	-	-	-	-	-	-	-	-	-	-	-	
In conformity with standards		IEC/EN 60947-2																
Utilization category		A				A				A				A				
Isolation function		■				■				■				■				
Ambient temperature		-35°C ~ +70°C																
Arcing distance		≤ 50				≤ 50				≤ 50				≤ 50				
Mechanical life (times)	Without maintenance	20000				20000				20000				20000				
	With maintenance	40000				40000				40000				40000				
Electrical life (times)	AC415V, In	10000				10000				10000				10000				
Release type and protection type	Magnetic release	Distribution protection	■	■	■	■	■	■	■	■	■	■	■	■	■	■	■	■
		Motor protection	■	■	■	■	■	■	■	■	■	■	■	■	■	■	■	■
	Thermal magnetic release	Distribution protection	■	■	■	■	■	■	■	■	■	■	■	■	■	■	■	■
		Motor protection	■	■	■	■	■	■	■	■	■	■	■	■	■	■	■	■
Accessories	Auxiliary contact	■	■	■	■	■	■	■	■	■	■	■	■	■	■	■	■	
	Alarm contact	■	■	■	■	■	■	■	■	■	■	■	■	■	■	■	■	
	Auxiliary contact, alarm contact	■	■	■	■	■	■	■	■	■	■	■	■	■	■	■	■	
	Shunt release	■	■	■	■	■	■	■	■	■	■	■	■	■	■	■	■	
	Under voltage release	■	■	■	■	■	■	■	■	■	■	■	■	■	■	■	■	
	Manual operational mechanism	■	■	■	■	■	■	■	■	■	■	■	■	■	■	■	■	
	Motor-driven mechanism	■	■	■	■	■	■	■	■	■	■	■	■	■	■	■	■	
	Rear connection	■	■	■	■	■	■	■	■	■	■	■	■	■	■	■	■	
	Plug-in type	■	■	■	■	■	■	■	■	■	■	■	■	■	■	■	■	
	Extending terminal bonding bar	■	■	■	■	■	■	■	■	■	■	■	■	■	■	■	■	
Derivative product	For special use of prepaid ammeter	■	-	■	■	■	-	■	■	■	-	■	■	■	-	■	■	
	Overload alarm non-trip	-	-	-	-	-	-	-	-	■	■	■	■	■	■	■	■	
Dimension and size(mm) Width (w) X height (H)X depth(D)	Width (2P/3P/4P)	56/78/103				56/78/103				63/90/120				78/105/140				
	Height	135				135				155				165				
	Depth (E/S/F/H type)	71/71/81/81				71/71/81/81				75.5/75.5/91/91				77/77/102/102				

Technical Parameters

NXMS series electronic moulded case circuit breaker

Frame size Inm(A)		160		250		400		
Rated current In(A),40°C		32, 63, 125, 160		250		400		
Rated insulation voltage Ui(V)		800		1000		1000		
Rated impulse withstand voltage Uimp(kV)		8		8		12		
Rated operational voltage Ue(V),AC 50/60Hz		220/230/240, 380/400/415, 690*		220/230/240, 380/400/415, 690*		220/230/240, 380/400/415, 690*		
Breaking capacity code		F	H	F	H	S	F	H
Number of poles	3P	■	■	■	■	■	■	■
	4P	■	■	■	■	■	■	■
Rated ultimate short circuit breaking capacity Icu(kA)	AC220/230/240	50	75	50	75	75	75	100
	AC380/400/415V	36	50	36	50	50	50	70
	AC690V	10	10	10	10	10	10	15
Rated service short circuit breaking capacity Ics(kA)	AC220/230/240	50	50	50	50	50	75	75
	AC380/400/415V	36	36	36	36	36	50	50
	AC690V	5	5	5	5	7.5	7.5	7.5
Rated shor-time withstand current Icw(kA),1s	AC400/415V	-	-	-	-	8		
In conformity with standard		IEC/EN 60947-2						
Utilization category		A		A		B		
Isolation function		■		■		■		
Ambient temperature		-25°C ~ +70°C						
Arcing distance		≤ 50		≤ 50		≤ 100		
Mechanical life (times)	Without maintenance	20000		20000		10000		
	With maintenance	40000		40000		20000		
Electrical life (times)	AC415V,In	10000		10000		8000		
Electric release (times)	Distribution protection	■		■		■		
	Motor protection	■		■		■		
Accessories	Auxiliary contact	■		■		■		
	Alarm contact	■		■		■		
	Auxiliary contact, alarm contact	■		■		■		
	Shunt release	■		■		■		
	Under voltage release	■		■		■		
	Communication module	■		■		■		
	Maintenance tester	■		■		■		
	Setting and monitoring software	■		■		■		
	Remote indication contact	■		■		■		
	Manual operational mechanism	■		■		■		
	Motor-driven mechanism	■		■		■		
	Rear connection	■		■		■		
	Plug-in type	■		■		■		
	Extending terminal bonding bar	■		■		■		
	Temperature monitoring module	■		■		■		
Interphase barrier	■		■		■			
Dimension and size (mm) Width x height x depth	Width (3P/4P)	90/120		105/140		140/185		
	Height	155		165		257		
	Depth (S/H type)	91/91		102/102		108.5/108.5		

*690V only has CE certification

Technical Parameters

NXMLE series residual current circuit breaker (Coming soon)

Frame size Inm(A)	125			160				
Rated operational current In (A), 40°C	10,16,20,25,32,40,50,63,80,100,125			32,40,50,80,100,125,140,160				
Rated insulation voltage Ui(V)	800			800				
Rated impulse withstand voltage Uimp(kV)	8			8				
Rated operational voltage Ue(V), AC 50/60Hz	220/230/240,380/400/415			220/230/240,380/400/415				
Rated residual operating current I Δn(mA)	Fixed single grade, non-delay type	30/50/100/200/300/500			30/50/100/200/300/500			
	Fixed single grade, delay type	50/100/200/300/500			50/100/200/300/500			
	Adjustable non-delay type	A:	30/50/100/200			A: 30/50/100/200		
		-	-			-		
		C:	100/200/300/500			C: 100/200/300/500		
	Adjustable non-delay type	B:	50/100/200/300			B: 50/100/200/300		
C:		100/200/300/500			C: 100/200/300/500			
-		-			-			
-		-			-			
Rated residual non-operating current I Δno(A)	0.5IΔn			0.5IΔn				
Non-delay type 5I Δn, maximum breaking time(s)	≤ 0.04			≤ 0.04				
Delayed adjustable 2I Δn limit non-actuating time (s)non-adjustable	0.1/0.2/0.3 , optional			0.1/0.2/0.3 , optional				
Delayed adjustable 2I Δn maximum breaking time	0.3/0.4/0.5 , optional			0.3/0.4/0.5 , optional				
Breaking capacity code	S	F	H	S	F	H		
Number of poles	1P+N	■	-	-	■	-	-	
	2P	■	-	-	■	-	-	
	3P	■	■	■	■	■	■	
	3P+N	■	■	■	■	■	■	
	4P	■	■	■	■	■	■	
Rated ultimate short circuit breaking capacity Icu(kA)	AC220/230/240	36	36	50	50	50	75	
	AC380/400/415	25	18	36	35	25	50	
Rated service short circuit breaking capacity Ics (kA)	AC220/230/240	18	36	36	30	50	50	
	AC380/400/415	13	18	18	18	25	25	
In conformity with standard	IEC/EN 60947-2							
Utilization category	A			A				
Isolation function ¹⁾	■			■				
Ambient temperature	-25°C ~+70°C							
Arcing distance	≤ 50			≤ 50				
Mechanical life (times)	Without maintenance	20000			20000			
	With maintenance	40000			40000			
	AC415V,In	10000			10000			
Accessories	Auxiliary contact (1open and 1closed)	■	■	■	■	■	■	
	Auxiliary contact (2open and 2closed)	-	-	-	■	■	■	
	Alarm contact	■	■	■	■	■	■	
	Auxiliary contact, alarm contact	■	■	■	■	■	■	
	Shunt release	■	■	■	■	■	■	
	Under voltage release	■	■	■	■	■	■	
	Residual current alarm with non-trip module	-	-	-	■	■	■	
	Manual operational mechanism	■	■	■	■	■	■	
	Motor-driven mechanism	■	■	■	■	■	■	
	Rear connection	■	■	■	■	■	■	
	Plug-in type	■	■	■	■	■	■	
	Extending terminal bonding bar	■	■	■	■	■	■	
	Interphase barrier	■	■	■	■	■	■	
Dimension and sizes(mm) width(W) x height(H) x depth(D)	Width (1PN/2P/3P/3PN/4P)	56/56/76/103/103			63/63/90/120/120			
	Height	156			160			
	Depth (S type and H type)	71/81			75.5/91			

Note: 1) 1PN/3PN has no isolation function.



250			400			630		
125,160,180,200,225,250			250,280,315,320,350,400			400,500,630		
800			800			800		
8			8			8		
220/230/240,380/400/415			220/230/240,380/400/415			220/230/240,380/400/415		
30/50/100/200/300/500			50/100/200/300/500/1000			50/100/200/300/500/1000		
50/100/200/300/500			50/100/200/300/500/1000			50/100/200/300/500/1000		
A: 30/50/100/200			B: 50/100/200			B: 50/100/200		
-			C: 100/200/300			C: 100/200/300		
C: 100/200/300/500			D: 200/300/500			D: 200/300/500		
-			E: 300/500/1000			E: 300/500/1000		
B: 50/100/200/300			B: 50/100/200			B: 50/100/200		
C: 100/200/300/500			C: 100/200/300			C: 100/200/300		
-			D: 200/300/500			D: 200/300/500		
-			E: 300/500/1000			E: 300/500/1000		
0.5IΔn			0.5IΔn			0.5IΔn		
≤ 0.04			≤ 0.04			≤ 0.04		
0.1/0.2/0.3 , optional			0.1/0.2/0.3 , optional			0.1/0.2/0.3 , optional		
0.3/0.4/0.5 , optional			0.3/0.4/0.5 , optional			0.3/0.4/0.5 , optional		
S	F	H	S	F	H	S	F	H
■	-	-	-	-	-	-	-	-
■	-	-	-	-	-	-	-	-
■	■	■	■	■	■	■	■	■
■	■	■	■	■	■	■	■	■
■	■	■	■	■	■	■	■	■
50	50	75	75	75	100	75	75	100
35	25	50	50	36	70	50	36	70
30	50	50	50	75	75	50	75	75
18	25	25	25	36	36	25	36	36
IEC/EN 60947-2								
A			A			A		
■			■			■		
-25°C ~ +70°C								
≤ 100			≤ 100			≤ 100		
20000			10000			10000		
40000			20000			20000		
10000			8000			8000		
■	■		■	■		■	■	
■	■		■	■		■	■	
■	■		■	■		■	■	
■	■		■	■		■	■	
■	■		■	■		■	■	
■	■		■	■		■	■	
■	■		■	■		■	■	
■	■		■	■		■	■	
■ ²⁾	■ ²⁾		■	■		■	■	
■	■		■	■		■	■	
■	■		■	■		■	■	
■	■		■	■		■	■	
78/78/105/140/140			-/-/140/185/185			-/-/140/185/185		
170			267			267		
77/80			108.5/108.5			108.5/108.5		

Technical Parameters

NXHM* series disconnecter switch (Coming soon)

Conventional thermal current I _{th} (A), 40°C		63	125	160
Rated current I _e (A)		63	125	160
Rated insulation voltage U _i (V)		800	800	800
Rated impulse withstand voltage U _{imp} (kV)		8	8	8
Rated operational voltage U _e (V), AC 50/60Hz		400/415	400/415	400/415,690
Number of poles		3P/4P	3P/4P	3P/4P
Rated short-time withstand current I _{CS} (peak value A) AC 400/415V		800	1500	2000
In conformity with standards		IEC/EN/ 60947-3		
Utilization category		AC-22A/AC-23A	AC-22A/AC-23A	AC-21A(B)/AC-22A(B)
Ambient temperature		-35°C ~ +70°C		
Arcing distance		≤ 50	≤ 50	≤ 50
Mechanical life (times)		Without maintenance	20000	20000
		With maintenance	40000	40000
Electrical life (times)		AC415V, I _n	10000	10000
Accessories		Auxiliary contact	■	■
		Alarm contact	■	■
		Auxiliary contact, alarm contact	■	■
		Shunt release	■	■
		Under voltage release	■	■
		Manual operational mechanism	■	■
		Motor-driven mechanism	■	■
		Rear connection	■	■
		Plug-in	■	■
		Extending terminal bonding bar	■	■
Dimension and sizes (mm Width(W) x height(H) x depth(D))		Width (3P//4P)	78/103	90/120
		Height	135	155
		Depth	71	75.5

*NXHM series product only has CE certification



250	400	630	800	1000
250	400	630	800	1000
1000	1000	1000	1000	1000
8	12	12	12	12
380/400/415/690	400/415/690	400/415/690	400/415/690	400/415/690
3P/4P	3P/4P	3P/4P	3P/4P	3P/4P
4000	5000	7800	10000	12000
IEC/EN 60947-3				
AC-21A(B)/AC-22A(B)	AC-21A(B)/AC-22A(B)	AC-21A(B)/AC-22A(B)	AC-21A(B)/AC-22A(B)	AC-21A(B)/AC-22A(B)
-35°C ~ +70°C				
≤ 50	≤ 100	≤ 100	≤ 100	≤ 100
20000	10000	10000	8000	5000
40000	20000	20000	10000	10000
10000	8000	8000	5000	2500
■	■	■	■	■
■	■	■	■	■
■	■	■	■	■
■	■	■	■	■
■	■	■	■	■
■	■	■	■	■
■	■	■	■	■
■	■	■	■	■
■	■	■	■	■
■	■	■	■	■
■	■	■	■	■
105/140	140/185	140/185	182/240	210/280
165	257	257	270	280
77	108.5	108.5	114	118

*NXHM series product only has CE certification

Protection Feature

Distribution protection – Only magnetic release

Only magnetic release	Frame size I_{nm} (A)	Rated current I_n (A)	Setting of short circuit protection current	Setting value of short circuit protection current I_i (A) and allowance	Release time
Short circuit protection	63	10~63	Fixed	$10I_n \pm 20\%$	Instantaneous action
	125	10~125	Fixed	$10I_n \pm 20\%$	
	160	32~160	Fixed	$10I_n \pm 20\%$	
	250	125~250	Fixed	$10I_n \pm 20\%$	
	400	250~400	Fixed	$10I_n \pm 20\%$	
	630	400~630	Fixed	$10I_n \pm 20\%$	
	800	630~800	Fixed	$10I_n \pm 20\%$	
	1000	800~1000	Fixed	$10I_n \pm 20\%$	
	1250	1000~1250	Adjustable	$I_i: (7-8-9-10) I_n$	
	1600	1000~1600	Adjustable	$I_i: (7-8-9-10) I_n$	

	Frame size I_{nm} (A)	Rated current I_n (A)	Setting of neutral pole protection current	Setting value of neutral pole short circuit protection current (A) and allowance	Release time
Neutral pole protection (code of N poles C/D)	63	10~63	Fixed	$I_i \pm 20\%$	Instantaneous action
	125	10~125	Fixed	$I_i \pm 20\%$	
	160	32~160	Fixed	$I_i \pm 20\%$	
	250	125~250	Fixed	$I_i \pm 20\%$	
	400	250~400	Fixed	$I_i \pm 20\%$	
	630	400~630	Fixed	$I_i \pm 20\%$	
	800	630~800	Fixed	$I_i \pm 20\%$	
	1000	800~1000	Fixed	$I_i \pm 20\%$	
	1250	1000~1250	Adjustable	$I_i: (7-8-9-10)I_n$	
	1600	1000~1600	Adjustable	$I_i: (7-8-9-10)I_n$	



Distribution protection—Thermal magnetic release

Thermal magnetic release	Frame size I_{nm} (A)	Rated current I_n (A)	Setting of overcurrent protection	Release feature
Overload protection	63A~1000A	10A~1000A	Fixed	I^2t =constant 1.05 I_n (cold state), 2h non-trip($I_n > 63A$), 1h non-trip($I_n \leq 63A$) 1.30 I_n (heat state), 2h trip($I_n > 63A$), 1h trip($I_n \leq 63A$)
	1600	1000A~1600A	Adjustable	I_r adjustable range: (0.7-0.8-0.9-1) I_n

Thermal magnetic release	Frame size I_{nm} (A)	Rated current I_n (A)	Setting of short circuit protection current	Setting value of short circuit protection current I_s (A) and allowance	Release time
Short circuit protection	63	10~63	Fixed	$10I_n, \pm 20\%$	Instantaneous action
	125	10~125	Fixed	$10I_n, \pm 20\%$	
	160	32~160	Fixed	$10I_n, \pm 20\%$	
	250	125~250	Fixed	$10I_n, \pm 20\%$	
	400	250~400	Fixed	$10I_n, \pm 20\%$	
	630	400~630	Fixed	$10I_n, \pm 20\%$	
	800	630~800	Fixed	$10I_n, \pm 20\%$	
	1000	800~1000	Fixed	$10I_n, \pm 20\%$	
	1250	1000~1250	Adjustable	$I_s : (7-8-9-10) I_n$	
	1600	1000~1600	Adjustable	$I_s : (7-8-9-10) I_n$	

	Frame size I_{nm} (A)	Rated current I_n (A)	Setting of neutral pole protection current	Setting value of neutral pole overload protection current(A) setting value neutral pole short circuit protection current(A)
Neutral pole protection (code of N pole C/ D)	63	10~63	Fixed	$I_r, I_s, \pm 20\%$
	125	10~125	Fixed	$I_r, I_s, \pm 20\%$
	160	32~160	Fixed	$I_r, I_s, \pm 20\%$
	250	125~250	Fixed	$I_r, I_s, \pm 20\%$
	400	250~400	Fixed	$I_r, I_s, \pm 20\%$
	630	400~630	Fixed	$I_r, I_s, \pm 20\%$
	800	630~800	Fixed	$I_r, I_s, \pm 20\%$
	1000	800~1000	Fixed	$I_r, I_s, \pm 20\%$
	1250	1000~1250	Adjustable	$I_s : (7-8-9-10) I_n$
	1600	1000~1600	Adjustable	$I_s : (7-8-9-10) I_n$

Protection Feature

Distribution protection—Electronic release

Electronic release	Frame size I_{nm} (A)	Rated current I_r (A)	Setting of overcurrent protection I_r (A)	Release feature/time
Overload long-time-delay protection	160	32	16-18-20-22-25-28-30-32	$I^2t = \text{constant}$ 1.05 I_r , no action within 2h 1.3 I_r , action with 1h 2 I_r , $t_r = (12-60-80-100)s$, $I_{nm} < 400A$ 2 I_r , $t_r = (12-60-100-150)s$, $I_{nm} \geq 400A$
		63	32-36-40-45-50-56-60-63	
		125	63-70-75-80-90-100-110-125	
		160	80-90-100-110-125-140-150-160	
	250	250	125-140-150-160-180-200-225-250	
	400	400	200-225-250-280-300-315-350-400	
	630	630	400-450-480-500-530-560-600-630	
	1000	800	630-660-680-700-720-750-780-800	
		1000	630-680-720-780-820-900-950-1000	
1250	1250	630-700-800-900-1000-1100-1200-1250		
1600	1600	800-900-1000-1100-1250-1400-1500-1600		
Action allowance				±10%
Short circuit short-time-delay protection	All series	32~1600	$I_{sd} = (1.5-2-3-4-5-6-8)I_r + \text{OFF}$	$t_{sd} = 0.3, \pm 0.06s$
Action allowance			±15%	
Instantaneous protection	160~1600	32~1600	$I_i = (2-3-4-6-8-10-12)I_r + \text{OFF}$	Instantaneous action
Action allowance			±15%	
Neutral pole protection (code of four pole C/D)	All series	32~1600	$I_{iN} = (0.5, 1)I_r + \text{OFF}$, Adjustable	
Indication of overload	All series	32~1600	$I_{io} = 1.2I_r$	



Distribution protection—Only magnetic release + residual current release

Only magnetic release	Frame size $I_{nm}(A)$	Rated current $I_n(A)$	Setting of short circuit protection current	Setting value of short circuit protection current $I_i(A)$ and allowance	Release time
Short circuit protection	125	10~125	Fixed	$10I \pm 20\%n$,	Instantaneous action
	160	125,160	Fixed	$10I \pm 20\%n$,	
	250	160~250	Fixed	$10I \pm 20\%n$,	
	400	315~400	Fixed	$10I \pm 20\%n$,	
	630	400~630	Fixed	$10I \pm 20\%n$,	
	800	630~800	Fixed	$10I \pm 20\%n$,	

	Frame size $I_{nm}(A)$	Residual current Release type	Residual current release type	Setting value of rated residual current $I_{\Delta n}$ (A)	Release time												
Residual action current protection	125/160/250	AC Type	Non delay: single grade and non-adjustable	30/50/100/200/300/500	<table border="1"> <tr> <td>Non-delay type $5I_{\Delta n}$ maximum breaking time(s)</td> <td colspan="3">≤ 0.4</td> </tr> <tr> <td>Delay type $2I_{\Delta n}$ limit non-driving time (s) Adjustable</td> <td>0.1</td> <td>0.2</td> <td>0.3</td> </tr> <tr> <td>Delay type $2I_{\Delta n}$ maximum breaking time(s) Adjustable</td> <td>0.3</td> <td>0.4</td> <td>0.5</td> </tr> </table>	Non-delay type $5I_{\Delta n}$ maximum breaking time(s)	≤ 0.4			Delay type $2I_{\Delta n}$ limit non-driving time (s) Adjustable	0.1	0.2	0.3	Delay type $2I_{\Delta n}$ maximum breaking time(s) Adjustable	0.3	0.4	0.5
			Non-delay type $5I_{\Delta n}$ maximum breaking time(s)	≤ 0.4													
			Delay type $2I_{\Delta n}$ limit non-driving time (s) Adjustable	0.1		0.2	0.3										
			Delay type $2I_{\Delta n}$ maximum breaking time(s) Adjustable	0.3		0.4	0.5										
	Three grades and adjustable	A/B/C/D															
	Delay type: single grade and non-adjustable	50/100/200/300/500															
	Three grades and adjustable	B/C/D															
	400/630	AC Type	Non delay: single grade and non-adjustable	50/100/200/300/500/1000													
Three grades and adjustable			B/C/D/E														
Delay type: single grade and non-adjustable			50/100/200/300/500/1000														
Three grades and adjustable			B/C/D/E														

Protection Feature

Distribution protection—Thermal magnetic r lease+ residual current release

Thermal magnetic release	Frame size I _{nm} (A)	Rated current I _n (A)	Overload protection current Setting	Release feature
Overload protection	All series	10A~800A	Fixed	I ² t=constant 1.05 I _n (cold state), 2h non-release(I _n > 63A),1h non-release(I _n ≤ 63A) 1.30 I _n (heat state), 2h release(I _n > 63A),1h release(I _n ≤ 63A)

	Frame size I(A)nm	Rated current I(A)n	Setting of short circuit protection current	Setting value of short circuit protection current I(A) iand allowance	Release time
Short circuit protection	125	10~125	Fixed	10I±20%n ,	Instantaneous action
	160	125,160	Fixed	10I±20%n ,	
	250	160~250	Fixed	10I±20%n ,	
	400	315~400	Fixed	10I±20%n ,	
	630	400~630	Fixed	10I±20%n ,	

	Frame size I(A)nm	Residual current release type	Setting value of rated residual current I(A)Δn	Release time													
Residual current protection	125/160/250	AC type	Non delay: single grade and non-adjustable	30/50/100/200/300/500	<table border="1"> <tr> <td>Non-delay type 5IΔn maximum breaking time(s)</td> <td colspan="3">≤ 0.4</td> </tr> <tr> <td>Delay type 2IΔn limit non-driving time (s) Adjustable</td> <td>0.1</td> <td>0.2</td> <td>0.3</td> </tr> <tr> <td>Delay type 2IΔn maximum breaking time(s) Adjustable</td> <td>0.3</td> <td>0.4</td> <td>0.5</td> </tr> </table>	Non-delay type 5IΔn maximum breaking time(s)	≤ 0.4			Delay type 2IΔn limit non-driving time (s) Adjustable	0.1	0.2	0.3	Delay type 2IΔn maximum breaking time(s) Adjustable	0.3	0.4	0.5
			Non-delay type 5IΔn maximum breaking time(s)	≤ 0.4													
			Delay type 2IΔn limit non-driving time (s) Adjustable	0.1		0.2	0.3										
			Delay type 2IΔn maximum breaking time(s) Adjustable	0.3		0.4	0.5										
	Three grades and adjustable	A/B/C/D															
	Delay type: single grade and non-adjustable	50/100/200/300/500															
	Three grades and adjustable	B/C/D															
	400/630	AC type	Non delay: single grade and non-adjustable	50/100/200/300/500/1000													
Three grades and adjustable			B/C/D/E														
Delay type: single grade and non-adjustable			50/100/200/300/500/1000														
Three grades and adjustable			B/C/D/E														



Motor protection—Only magnetic release

Only magnetic release	Frame size I(A)nm	Rated current I(A)n	Setting of short circuit protection current	Setting value of short circuit protection current I(A) and allowance <i>i</i>	Release time
Short circuit protection	63	10~63	Fixed	$12I_n, \pm 20\%$	Instantaneous action
	125	10~125	Fixed	$12I_n, \pm 20\%$	
	160	32~160	Fixed	$12I_n, \pm 20\%$	
	250	125~250	Fixed	$12I_n, \pm 20\%$	
	400	250~400	Fixed	$12I_n, \pm 20\%$	
	630	400~630	Fixed	$12I_n, \pm 20\%$	
	800	630~800	Fixed	$12I_n, \pm 20\%$	

	Frame size $I_{nm}(A)$	Rated current $I_n(A)$	Setting of neutral pole protection current	Setting value of neutral pole overload protection current(A) Setting value neutral pole short circuit protection current(A)
Neutral pole protection (code of N pole C/D)	63	10~63	Fixed	$I_n, I_r, \pm 20\%$
	125	10~125	Fixed	$I_n, I_r, \pm 20\%$
	160	125,160	Fixed	$I_n, I_r, \pm 20\%$
		125,160	Fixed	$I_n, I_r, \pm 20\%$
	250	160~250	Fixed	$I_n, I_r, \pm 20\%$
	400	315~400	Fixed	$I_n, I_r, \pm 20\%$
	630	400~630	Fixed	$I_n, I_r, \pm 20\%$
	800	630~800	Fixed	$I_n, I_r, \pm 20\%$

Protection Feature

Motor protection—Thermal magnetic release

Thermal magnetic release	Frame size I (A)nm	Rated current I (A)n	Setting of overcurrent protection	Release feature
Overload protection	125~800	25~630A	Fixed	$I_2t = \text{constant}$ 1.0In(cold state), > 2h non release 1.2In(hot state), ≤ 2h release 7.2In(hot state), 4s ≤ T ≤ 10s, 10A ≤ In ≤ 225A 6s ≤ T ≤ 20s, 225A < In ≤ 630A(including 800A frame 630A) Trip class: 10(≤ 160A), 20(160A < In ≤ 630 A)

Thermal magnetic release	Frame size I (A)nm	Rated current I (A)n	Setting of short circuit protection current	Setting value of short circuit protection current I(A) and allowance <i>ei</i>	Release time
Short circuit protection	63	10~63	Fixed	$12I_n, \pm 20\%$	Instantaneous action
	125	10~125	Fixed	$12I_n, \pm 20\%$	
	160	32~160	Fixed	$12I_n, \pm 20\%$	
	250	125~250	Fixed	$12I_n, \pm 20\%$	
	400	250~400	Fixed	$12I_n, \pm 20\%$	
	630	400~630	Fixed	$12I_n, \pm 20\%$	
	800	630~800	Fixed	$12I_n, \pm 20\%$	

	Frame size I (A)nm	Rated current I (A) n	Setting of neutral pole protection current	Setting value of neutral pole overload protection current(A) Setting value neutral pole short circuit protection current(A)
Neutral pole protection (code of N pole C/D)	63	10~63	Fixed	$I_r, I_i, \pm 20\%$
	125	10~125	Fixed	$I_r, I_i, \pm 20\%$
	160	125,160	Fixed	$I_r, I_i, \pm 20\%$
		125,160	Fixed	$I_r, I_i, \pm 20\%$
	250	160~250	Fixed	$I_r, I_i, \pm 20\%$
	400	315~400	Fixed	$I_r, I_i, \pm 20\%$
	630	400~630	Fixed	$I_r, I_i, \pm 20\%$
	800	630~800	Fixed	$I_r, I_i, \pm 20\%$



Motor protection—Electronic release

Electronic release	Frame size I _{nm} (A)	Rated current I _n (A)	Setting of overcurrent protection I _r (A)	Release feature/time
Overload long-time-delay protection	160	32	16-18-20-22-25-28-30-32	I ² t=constant 1.05I _r No actuation within 2h 1.2I _r Actuation within 1h Release class 10A 10 20 30 1.5I _r 53 107 178 267 2I _r 30 60 100 150 7.2I _r 2.3 4.6 7.7 11.6 Delay time accuracy: ±20%
		63	32-36-40-45-50-56-60-63	
		100	63-70-75-80-85-90-95-100	
		125	63-70-75-80-90-100-110-125	
		160	80-90-100-110-125-140-150-160	
		200	100-125-140-150-160-170-180-200	
	250	250	125-140-150-160-180-200-225-250	
	400	400	200-225-250-280-300-315-350-400	
630	630	400-450-480-500-530-560-600-630		
Operation allowance				±20%
Short circuit short-time-delay protection	160~630	32~630	I _{sd} =(1.5-2-3-4-5-6-8)I _r +OFF	t _{sd} =0.3,±0.06s
Operation allowance			±15%	
Instantaneous protection	160~630	32~630	I _i =(2-4-6-8-10-12-14)I _r +OFF	Instantaneous action
Operation allowance			±15%	
Neutral pole protection (N pole code C/D)	160~630	32~630	I _{rN} = (0.5, 1)I _r +OFF, adjustable	
Overload indication	160~630		I ₀ = 1.2I _r	

Protection Feature

Motor protection—Only magnetic release + r esidual current release

Only magnetic release	Frame size I (A)nm	Rated current I (A)n	Setting of short circuit protection current	Setting value of short circuit protection current I (A) and allowancei	Release time
Short circuit protection	125	10~125	Fixed	$12I_{n,r} \pm 20\%$	Instantaneous action
	160	125,160	Fixed	$12I_{n,r} \pm 20\%$	
	250	160~250	Fixed	$12I_{n,r} \pm 20\%$	
	400	315~400	Fixed	$12I_{n,r} \pm 20\%$	
	630	400~630	Fixed	$12I_{n,r} \pm 20\%$	

	Frame size I_{nm} (A)	Residual current Release type	Residual current release type	Setting value of rated residual current $I_{\Delta n}$ (A)	Release time												
Residual action current protection	125/160/250	AC type	Non delay: single grade and non-adjustable	30/50/100/200/300/500	<table border="1"> <tr> <td>Non-delay type $5I_{\Delta n}$ maximum breaking time(s)</td> <td colspan="3">≤ 0.4</td> </tr> <tr> <td>Delay type $2I_{\Delta n}$ limit non-driving time (s) Adjustable</td> <td>0.1</td> <td>0.2</td> <td>0.3</td> </tr> <tr> <td>Delay type $2I_{\Delta n}$ maximum breaking time(s) Adjustable</td> <td>0.3</td> <td>0.4</td> <td>0.5</td> </tr> </table>	Non-delay type $5I_{\Delta n}$ maximum breaking time(s)	≤ 0.4			Delay type $2I_{\Delta n}$ limit non-driving time (s) Adjustable	0.1	0.2	0.3	Delay type $2I_{\Delta n}$ maximum breaking time(s) Adjustable	0.3	0.4	0.5
			Non-delay type $5I_{\Delta n}$ maximum breaking time(s)	≤ 0.4													
			Delay type $2I_{\Delta n}$ limit non-driving time (s) Adjustable	0.1		0.2	0.3										
			Delay type $2I_{\Delta n}$ maximum breaking time(s) Adjustable	0.3		0.4	0.5										
	Three grades and adjustable	A/B/C/D															
	Delay type: single grade and non-adjustable	50/100/200/300/500															
	Three grades and adjustable	B/C/D															
	400/630	AC type	Non delay: single grade and non-adjustable	50/100/200/300/500/1000													
Three grades and adjustable			B/C/D/E														
Delay type: single grade and non-adjustable			50/100/200/300/500/1000														
Three grades and adjustable			B/C/D/E														

Motor protection—Thermal magnetic release+ r esidual current release

Thermal magnetic release	Frame size I_{nm} (A)	Rated current I_n (A)	Overload protection current setting	Release feature
Overload protection	125~800	25A~630A	Stationary	$I^2t = \text{constant}$ 1.0 I_n (cold state), >2h non release 1.2 I_n (hot state), ≤ 2 h release 1.5 I_n (hot state), ≤ 4 min, $10A \leq I_n \leq 225A$ ≤ 8 min, $225A < I_n \leq 630A$ (including 800A housing 630A) 7.2 I_n (hot state), $4s \leq T \leq 10s$, $10A \leq I_n \leq 225A$ $6s \leq T \leq 20s$, $225A < I_n \leq 630A$ (including 800A housing 630A) release class: 10 ($\leq 160A$), 20 ($160A < I_n \leq 630A$)



Motor protection—Thermal magnetic release+ residual current release

Thermal magnetic release	Frame size I_{nm} (A)	Rated current I_n (A)	Setting of short circuit protection current	Setting value of short circuit protection current I_i (A) and allowance	Release time
Short circuit protection	63	10~63	Stationary	$12I_n, \pm 20\%$	Instantaneous action
	125	10~125	Stationary	$12I_n, \pm 20\%$	
	160	125,160	Stationary	$12I_n, \pm 20\%$	
		125,160	Stationary	$12I_n, \pm 20\%$	
	250	160~250	Stationary	$12I_n, \pm 20\%$	
	400	315~400	Stationary	$12I_n, \pm 20\%$	
	630	400~630	Stationary	$12I_n, \pm 20\%$	

	Frame size I_{nm} (A)	Residual current release type	Residual current release type	Setting value of rated residual current $I_{\Delta n}$ (A)	Trip time												
Residual current protection	125/160/250	AC type	Non delay: single grade and non-adjustable	30/50/100/200/300/500	<table border="1"> <tr> <td>Non-delay type $5I_{\Delta n}$ maximum breaking time(s)</td> <td colspan="3">≤ 0.4</td> </tr> <tr> <td>Delay type $2I_{\Delta n}$ limit non-driving time (s) Adjustable</td> <td>0.1</td> <td>0.2</td> <td>0.3</td> </tr> <tr> <td>Delay type $2I_{\Delta n}$ maximum breaking time(s) Adjustable</td> <td>0.3</td> <td>0.4</td> <td>0.5</td> </tr> </table>	Non-delay type $5I_{\Delta n}$ maximum breaking time(s)	≤ 0.4			Delay type $2I_{\Delta n}$ limit non-driving time (s) Adjustable	0.1	0.2	0.3	Delay type $2I_{\Delta n}$ maximum breaking time(s) Adjustable	0.3	0.4	0.5
			Non-delay type $5I_{\Delta n}$ maximum breaking time(s)	≤ 0.4													
			Delay type $2I_{\Delta n}$ limit non-driving time (s) Adjustable	0.1		0.2	0.3										
			Delay type $2I_{\Delta n}$ maximum breaking time(s) Adjustable	0.3		0.4	0.5										
	Three grades and adjustable	A/B/C/D															
	Delay type: single grade and non-adjustable	50/100/200/300/500															
	Three grades and adjustable	B/C/D															
	400/630	AC type	Non delay: single grade and non-adjustable	50/100/200/300/500/1000													
Three grades and adjustable			B/C/D/E														
Delay type: single grade and non-adjustable			50/100/200/300/500/1000														
Three grades and adjustable			B/C/D/E														

Inner Accessories

AX auxiliary contact

Function: Remote indication of "ON" , "OFF" position of the breaker, connect to the control circuit of breaker.

Model description

AX- □ □ □ □

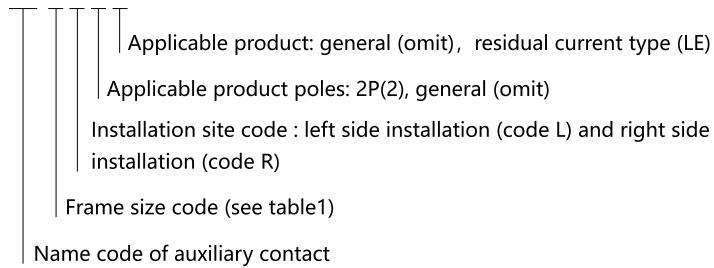
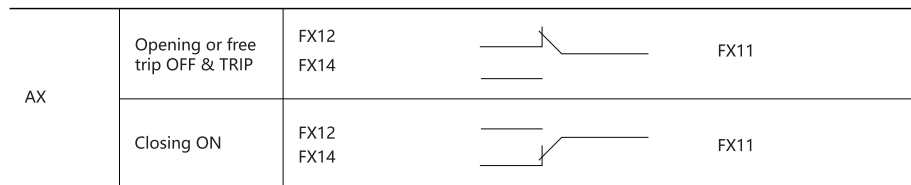

Table1 Frame size code

Frame size	63/125	160	250	400/630	800	1000	1250/1600
Code	M1	M2	M3	M4	M5	M6	8/M8

For example: 63/125 frame right auxiliary contact code: AX-M1R

To indicate the "ON" or "OFF" state of circuit breaker



Electrical characteristics

Operational voltage (V)		AC-15		DC-13	
		AC380/400/415		DC110	DC220/250
Operational current (A)	63~320	0.26		0.14	0.14
	400~1000	0.4		0.2	0.2
	1250,1600	0.47		0.27	0.27

Wiring diagram

Auxiliary contact can be wired with indicator light.
 The operator can know the location of switch " ON " or " OFF " without open the power distribution cabinet via indicator light.

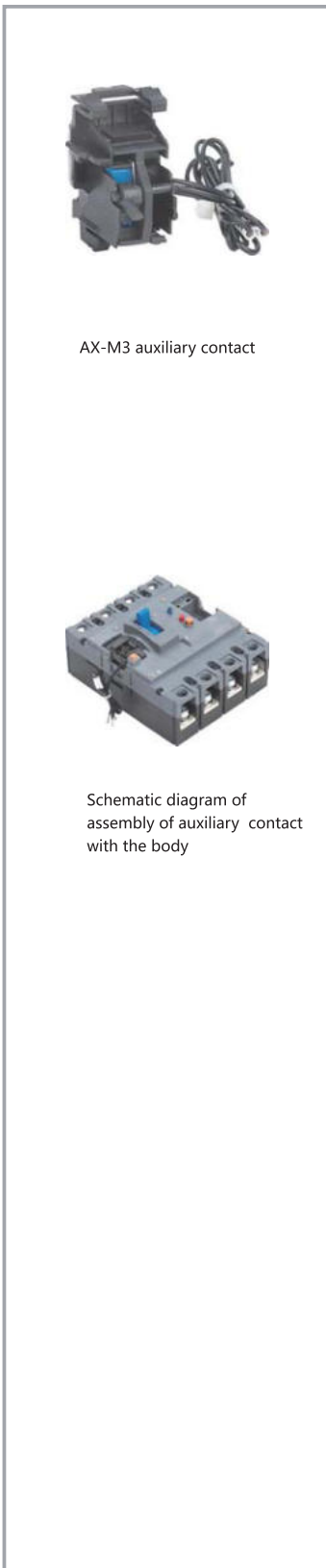
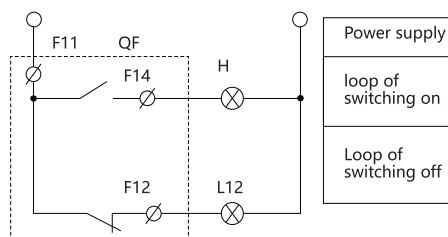



AL-M6 alarm contact



Schematic diagram of assembly of alarm contact with the body

Inner Accessories

AL alarm contact

Function: It is mainly used to provide signal in case of failure of circuit breaker or free trip.
Reasons for alarm contact to send failure indication signal:

- Overload or short circuit trip
- Under voltage trip
- Residual current operated trip
- Manual free trip

Model description

AX- □ □ □ □

Applicable product: general (omit), residual current type (LE)

Applicable product poles: 2P(2), general (omit)

Installation site code : left side installation (code L) and right side installation (code R)

Frame size code (see table1)

Name code of alarm contact

For instance: the left alarm contact code of 63/125 frame is: AL-M1L

Table1 frame size code

Frame size	63/125	160	250	400/630	800	1000	1250/1600
Code	M1	M2	M3	M4	M5	M6	8/M8

To indicate the "ON" or "OFF " state of circuit breaker

AL	Open or close OFF & ON	B12 B14		B11
	TRIP	B12 B14		B11

Electrical characteristics

Operational voltage (V)	AC-15		DC-13	
	AC380/400/415	DC110	DC220/250	
Operational current (A)	63~320	0.26	0.14	0.14
	400~1000	0.4	0.2	0.2
	1250,1600	0.47	0.27	0.27

Wiring diagram

Alarm contact can be connected with indicator light, buzzer and the like, and thus the operator can be timely informed in case of release of circuit breaker.

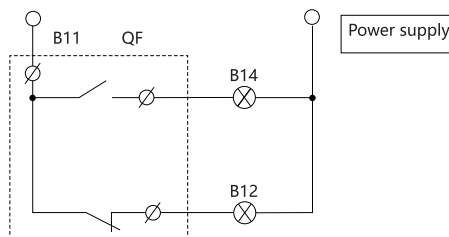



UV T-M4 under voltage release



Schematic diagram of assembly of under voltage release and non-release module with the body

Inner Accessories

UVT under voltage release

Function: To switch off the circuit breaker in case of under voltage of power supply so as to protect the electric equipment.

- The under voltage release shall switch off the circuit breaker reliably when the power supply voltage decreases (or even decrease slowly) to 70%-35% of rated control power supply voltage.
- It shall ensure the closing of breaker when the power supply voltage equals to or is more than 85% of rated control power supply voltage of under voltage release.
- The under voltage release shall be able to prevent closing of circuit breaker when the supply voltage is less than 35% of rated control supply voltage of under voltage release.

Model description

UVT- □ □ □ □

Applicable product: Thermal-magnetic (omit), residual current type(LE): Electronic(E)

Applicable product poles: 2P(2), general (omit)

Installation site code : left side installation (code L) and right side installation (code R)

Applicable voltage code (see table2, only A1, A2 are applicable)

Frame size code (see table1)

Name code of under voltage release

Table2 Applicable voltage code

For example: right under voltage release code of 63/125 frame 400V: UV T-M1A2

Table1 frame size code

Frame size	63/125	160	250	400/630	800	1000	1250/1600
Code	M1	M2	M3	M4	M5	M6	M7

Voltage	AC220V/230V/240V	AC380V/400V/415V
Code	A1	A2

Electrical characteristics

Frame size (A)	Under voltage release code (VA or W)	
	AC220V/230V/240V	AC380V/400V/415V
63/125	3.1	4
160	3.2	3.9
250/320	3.3	4.3
400/630	2.5	3.6
800	1.6	2
1000	1.6	2
1600	1.6	2

Operating characteristics

Operating conditions (XU ₆)	Switching off reliably	35%~70%
	Preventing closing	≤ 35%
	Closing reliably	≥ 85%
Response time		1s
Operation times		1000

Wiring diagram

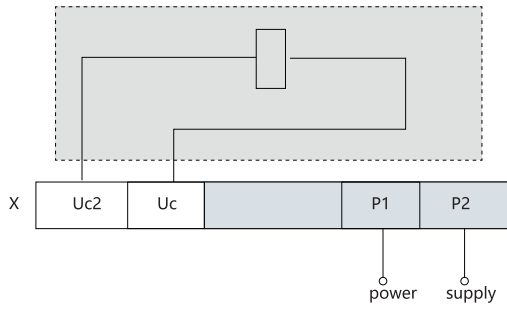



SHT-M2 shunt release



Schematic diagram of assembly of shunt release with the body

Inner Accessories

SHT shunt release

Function: Shunt release is an accessory for remote control.

The shunt release shall be able to make circuit breaker operating reliably when the power voltage equals to any voltage within the range of 70%~110% of rated control power voltage.

Model description

SHT- □ □ □ □ □

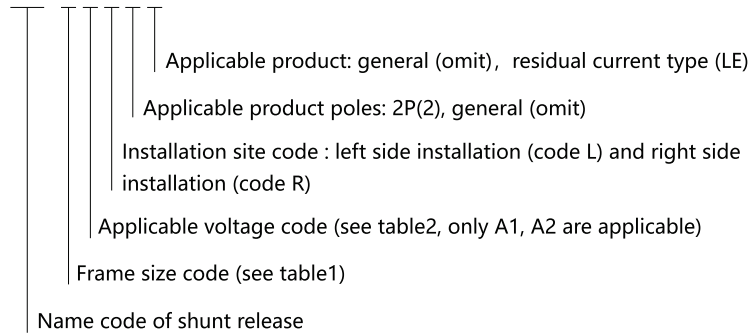

For example: left shunt release code of 63/125 housing 400V: SHT-M1A2L

Table1 frame size code

Frame size	63/125	160	250	400/630	800	1000	1250/1600
Code	M1	M2	M3	M4	M5	M6	M7

Table2 Applicable voltage code

Voltage	AC220V/230V/240V	AC380V/400V/415V	DC24V	DC110V	DC220V
Code	A1	A2	D1	D2	D3

Electrical characteristics

Frame size(A)	Code of under voltage release (VA or W)				
	AC220V/230V/240V	AC380V/400V/415V	DC24V	DC110V	DC220V
63/125	76	91.5	91	80	136
160	73	96.5	91	52.8	71
250/320	68.5	112	85.3	58	66
400/630	62.5	68	100	105	56
800	153	168	120	105	56
1000	153	163	120	105	56
1250/1600	175	183	140	143	286

Operating characteristics

Reliable operating voltage		70%~110%XUs
Conduction time (pulse mode)	minimum	10ms
	maximum	1s
Response time		30ms
Number of operations		1000

Wiring diagram

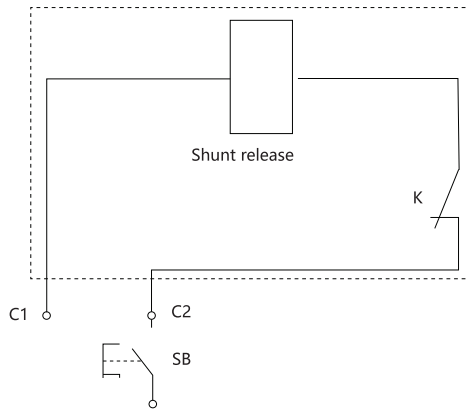



MD-M2 electric operational mechanism



Schematic diagram of assembly of motor-driven mechanism with the body

External Accessories

MD motor-driven mechanism

Function: it is applicable for switching circuit breaker on and off and retrip remotely, as well as automation application.

Model description

MD - □ □ □ □

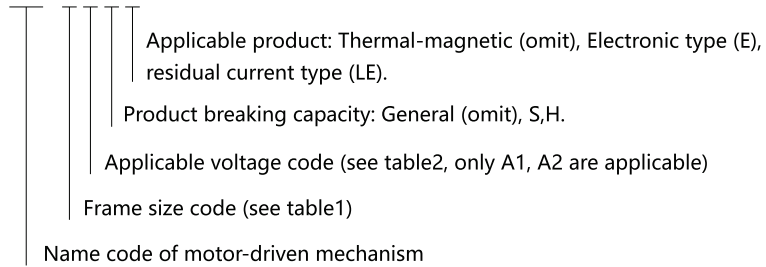

For example: motor driven code of 63/125 frame moulded case circuit breaker 400V: MD-M1A2

Table1 frame size code

Frame size	63/125	160	250	400/630	800	1000	1250/1600
Code	M1	M2	M3	M4	M5	M6	M7

Table2 Applicable voltage code

Voltage	AC220V/230V/240V	AC380V/400V/415V	DC24V	DC110V	DC220V
Code	A1	A2	D1	D2	D3

Electrical characteristics

Category	Model	All series
Structural style		DC-AC
Voltage specification		AC110V, 230V, 400V, AC220V, 230V, 240V, AC380V, 400V, 415V, DC24V, 110V, 220V, DC110V, 220V
Rated frequency		50/60 Hz

Wiring diagram

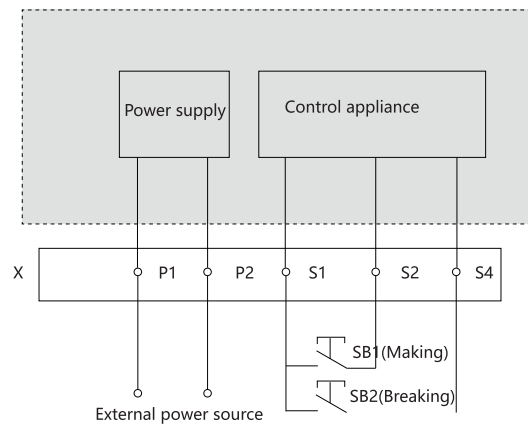

Description: SB1, SB2 is separately the on and off button;

P1, P2 are the external power line terminal. P1 will be connected to "+", and P2 will be connected to "-" if the external power source is DC.

Motor-driven mechanism

Installation sketch of electric operational mechanism

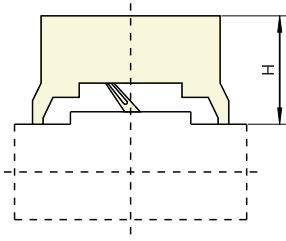

Frame size	63A	160A	250A	400A	800A	1000A	1250/1600A
	125A			630A			
Installation size H(mm)	92	97	97.5	154	153	154.5	156



External Accessories

ERH manual operational mechanism

Function: It realizes switching on, off and restriping via rotary handle according to human body mechanics with unique design and transmission device.

Model description

ERH - □ □

Category code of adaptive products: thermal magnetic type;
 electronic type (no code)
 residual current (code LE)

Frame size (table 1)

Name code of manual operational mechanism

For example: manual operational mechanism code of 63/125 frame residual current operating: ERH-M1LE

Table1 frame size code

Frame size	63/125	160	250	400/630	800	1000	1250/1600
Code	M1	M2	M3	M4	M5	M6	M7

Installation diagram of manual operational mechanism

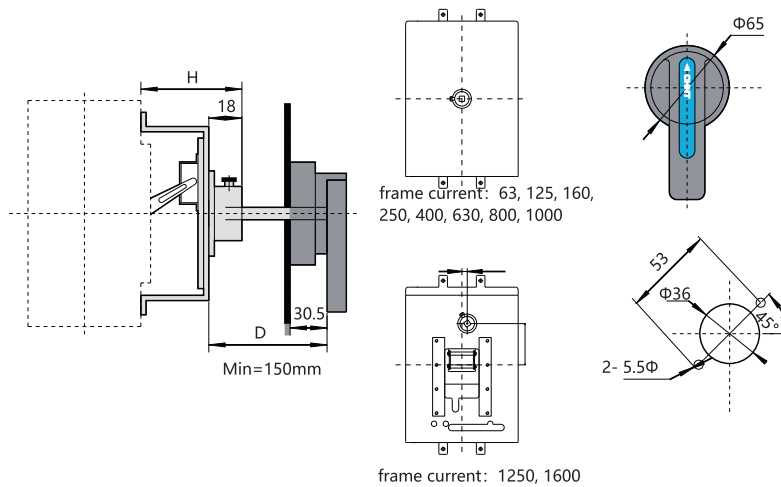

ERH-M6



Scheme diagram of assembly of manual operational mechanism with the body



PIA-M2

Frame size	63A	160A	250A	400A	800A	1000A	1250/1600A
	125A			630A			
Installation sizes(mm)	53.5	61.5	63.5	98	97	97	68.5



PIA plug-in basement

Function: It is convenient to replace moulded case circuit breaker without disassembling inlet-outlet line.

Model description

PIA- □ □

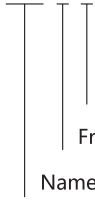

Applicable product poles: 3(3p),4(4p)

Frame size code(see table1)

Name code of plug-in basement

For example: plug-in basement code of 160 frame three-pole circuit breaker: PIA-M2 3

Frame size code

Frame size	63/125	160	250	400/630	800	1000	1250/1600
Code	M1	M2	M3	M4	M5	M6	M7

External Accessories

FCP front connection plate

Function: It grants the breaker a flexible line connecting way. The phase spacing can increase via accessories so as to increase the electrical space between the adjacent phases of line terminal of input and output of breaker, and thus increase the safety among the lines.

Model description

FCP - □ □

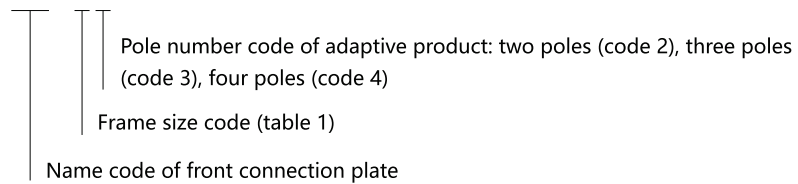

For example: 63/125 frame three-pole circuit front connection place code: FCP-M13

Table1 frame size code

Frame size	63/125	160	250	400/630	800	1000	1250/1600
Code	M1	M2	M3	M4	M5	M6	M7

RCP rear connection plate

Function: It grants the breaker with flexible line connecting way, which is used to match the switch board or other requirements so as to realize the line connecting on the back of the installation plate.

Model description

FCP - □ □

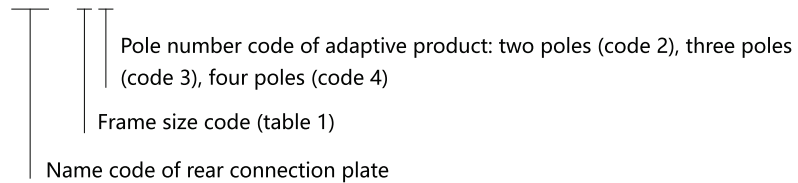

For example: 63/125 frame three-pole circuit breaker with rear connection plate code: RCP-M 13

Table1 frame size code

Frame size	63/125	160	250	400/630	800	1000	1250/1600
Code	M1	M2	M3	M4	M5	M6	M7





External Accessories

Handheld test module (PTU-1)

Handheld test module is the extension of the circuit breaker function, it can connection circuit breaker through USB interface, also the information of circuit breaker can be displayed in the handheld test module. User can query and set the parameters of the circuit breaker as needed. Users can easily monitor and repair the circuit breaker.

- Features:
- Query the factory parameters, shell current, rated current, communication address and other informations of the circuit breaker;
- Query overload long delay, short delay, short circuit instantaneous, N phase protection, ground fault current value, operating time and other settings parameters;
- Query real-time phase current value of the circuit breaker ABCN phase, the last fault alarm current parameter value;
- Set the protection characteristic parameter of circuit breaker. (Not available for Dial-type electronic circuit breakers);
- Can set the display brightness, screensaver power, serial communication parameters and circuit breaker communication address;
- Circuit breaker analog signal trip test.

characteristic:

Power supply	Single 14500 lithium-ion battery
Battery capacity	≥ 800mAh
Operational Voltage	3.7 ~ 4.2V
Charging method	USB +5V
Control mode	Pushbutton
LCD screen	3.2 inch TFT color, vertical screen display 1~100 level
Backlight brightness	adjustment
Screensaver saving	30 to 120 seconds can be set, can be closed
Battery power monitoring	Yes
Continuous working hours	2h
Operating temperature	-25°C ~ +70°C
Wired communication	Protocol: Modbus-RTU Serial communication rate: 1200/2400/4800/9600/19200bps

- Operating:
- Use five navigation keys with three shortcuts and one power key, it can provide users with simple and quick operation experience;
- The five navigation keys default to up, down, left, right, and confirmation;
- The three shortcut keys are R, W, T, respectively, for the read parameters, set the parameters of the test test trip;
- Power key press two seconds to switch operation, and operating tips are on the bottom of each pages.

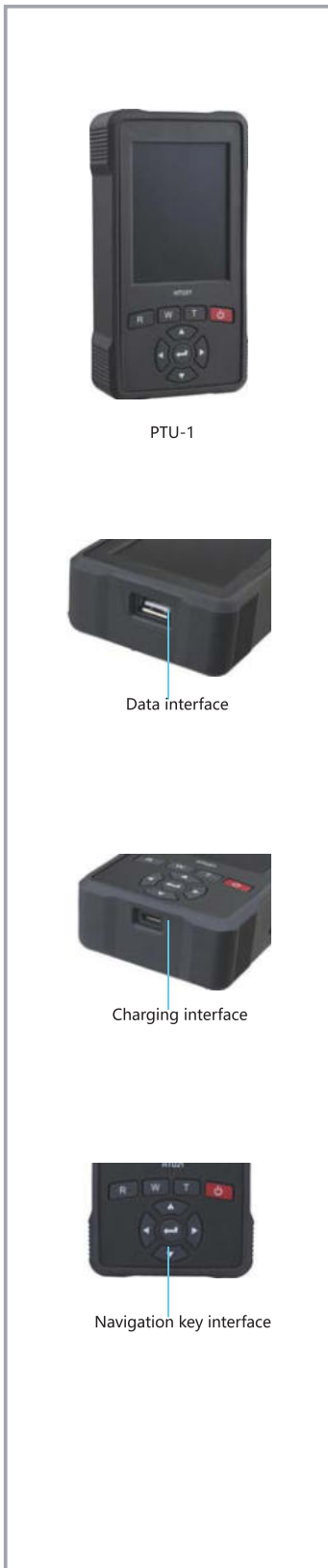

Complementary Technical Data

Altitude reducing capacity and correction coefficient table

It has no impact on the breaker feature where the altitude equals to 2000 m or below. The breaker electrical feature shall be corrected according to the following table.

Altitude (m)	2000	3000	4000	5000
Correction coefficient of operating current	1In	0.94In	0.88In	0.85In
Maximum operational voltage (V)	690	600	500	440
Insulation voltage (V)	1000	800	700	600
Power frequency withstand voltage (V)	2800	1500	1000	800

Plug-in and rear connection current derating table

Frame size	Rated current(A)	Plug-in derating current(A)	Note
630	500	450	
	630	520	
800	700	650	
	800	720	
1000	900	850	
	1000	920	

Note: There is no need of current derating as no specification in the table

Altitude derating curve

Maximum operation

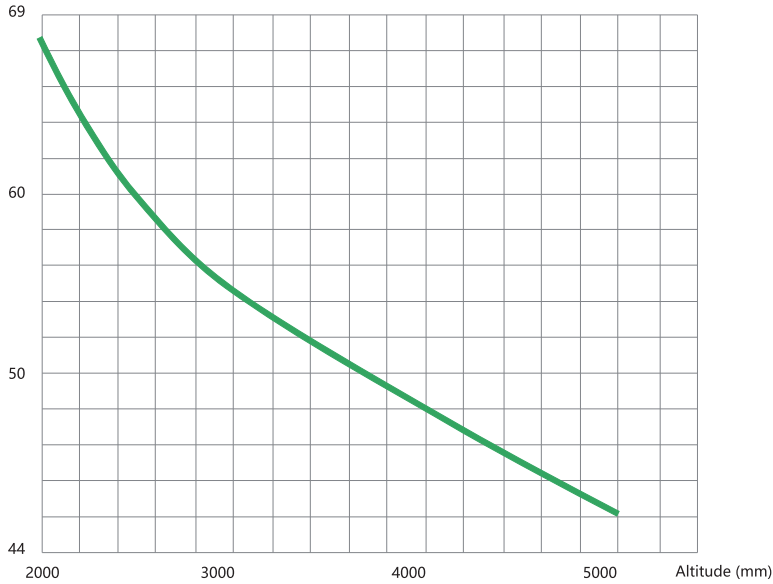

Electronic type derating coefficient table

Frame size	Rated current	Long-time delay current setting	-25°C	-20°C	-15°C	-10°C	-5°C	-0°C	Rated current	40°C	45°C	50°C	55°C	60°C	65°C	70°C	
NXMS-160	32A, 63A, 125A, 160A	$I_R < 0.65I_n$	$1.2I_R$	$1.2I_R$	$1.1I_R$	$1.1I_R$	$1.05I_R$	$1.05I_R$	32A, 63A, 125A	1.0In			0.9In	0.85In	0.8In	0.8In	
		$I_R > 0.65I_n$	$1.0I_R$						160A	1.0In	0.9In	0.85In	0.8In	0.7In	0.7In		
NXMS-250	250A	$I_R < 0.58I_n$	$1.15I_R$	$1.15I_R$	$1.15I_R$	$1.05I_R$	$1.05I_R$	$1.05I_R$	250A	1.0In			0.9In	0.85In	0.8In	0.8In	
		$I_R > 0.58I_n$	$1.0I_R$														
NXMS-630	400A, 630A	ALL	$1.0I_R$						400A	1.0In			0.9In	0.85In	0.8In	0.8In	
			630A	1.0In	0.9In	0.85In	0.8In	0.7In	0.7In								
NXMS-1000	800A, 1000A	ALL	$1.0I_R$						800A	1.0In			0.9In	0.85In	0.8In	0.8In	



Power loss table

Product model	Making current(A)	Single pole resistance (mΩ)	3/4pole total power loss		
			Front connection	Rear connection	Plug-in rear connection
NXM-63	63	0.75	24	27	28
NXM-125	125	0.72	28	31	32
NXM-160	160	0.4	60	87	89
NXM-250	250	0.2	63	90	90
NXM-400	400	0.15	68	72	100
NXM-630	630	0.14	180	190	200
NXM-800	800	0.08	200	230	290
NXM-1000	1000	0.06	250	280	300
NXM-1600	1600	0.027	280	-	-
NXMS-160	160	0.38	40	50	62
NXMS-250	250	0.3	50	75	86
NXMS-400	400	0.13	58	87	90
NXMS-630	630	0.07	110	120	130
NXMS-1000	1000	0.05	140	155	167
NXMS-1600	1600	0.027	250	-	-
NXMLE-160	160	0.73	60	87	89
NXMLE-250	250	0.27	63	90	90
NXMLE-400	400	0.11	68	72	100
NXMLE-630	630	0.09	180	190	200
NXHM-63	63	0.4	28	31	35
NXHM-125	125	0.6	60	87	87
NXHM-160	160	0.2	40	50	62
NXHM-250	250	0.18	50	75	86
NXHM-400	400	0.1	58	87	90
NXHM-630	630	0.08	110	120	130
NXHM-800	800	0.05	200	230	290
NXHM-1000	1000	0.02	140	155	167

Parameter table of connecting cable/copper bar

The reference section of connecting cable/copper bar with different rated current is as follows.

Rated current (A)	Section of wire (mm ²)
10	1.5
16, 20	2.5
25	4.0
32	6.0
40, 50	10
63	16
80	25
100	35
125, 140	50
160	70
180, 200, 225	95
250	120
280 315, 320, 350	185
400	240

Rated current (A)	Cable		Copper bar	
	Section (mm ²)	Quantity	Width x thickness (mm)	Quantity
500	150	2	30×5	2
630	185	2	40×5	2
700, 800	240	2	50×5	2
			50×10	1
900,1000	-	-	50×5	3
			63×10	1
1250	-	-	50×5	3
			40×10	2
1600	-	-	60×5	4
			60×10	2

The above reference section is the reference value under 40 degrees operating environmental temperature.
 The recommended value of tightening torque of different housing current connecting cable/copper bar is as follows:

Rated current (A)	63A/125A	160A	250A/320A	400A/630A	800A	1000A	1250A/1600A
Torque (N m) ¹⁾	3/6 ⁴⁾	10	12	30	30	40	30
Torque (N m) ²⁾	3/6 ⁴⁾	10	12	30	30	40	30
Torque (N m) ³⁾	3/6 ⁴⁾	10	12	30	30	40	30

- ¹⁾ Tighten the torque of busbar (or extension busbar/connection lug) in case of connecting with the body directly.
- ²⁾ Tighten the torque of connecting terminal behind the stationary breaker/tighten the torque of connecting terminal of plug in breaker.
- ³⁾ Tighten the torque of extension busbar of terminal on the plug-in pedestal.
- ⁴⁾ Value of torque is 3 for 10A~63A of frame current 63 and 125A breaker, value of torque is 6 for 70A~125A for frame current 125A breaker.



NXM- 63E/S/F/H, 125E/S/F/H, NXHM- 63, 125

Front connection, dimension (mm)

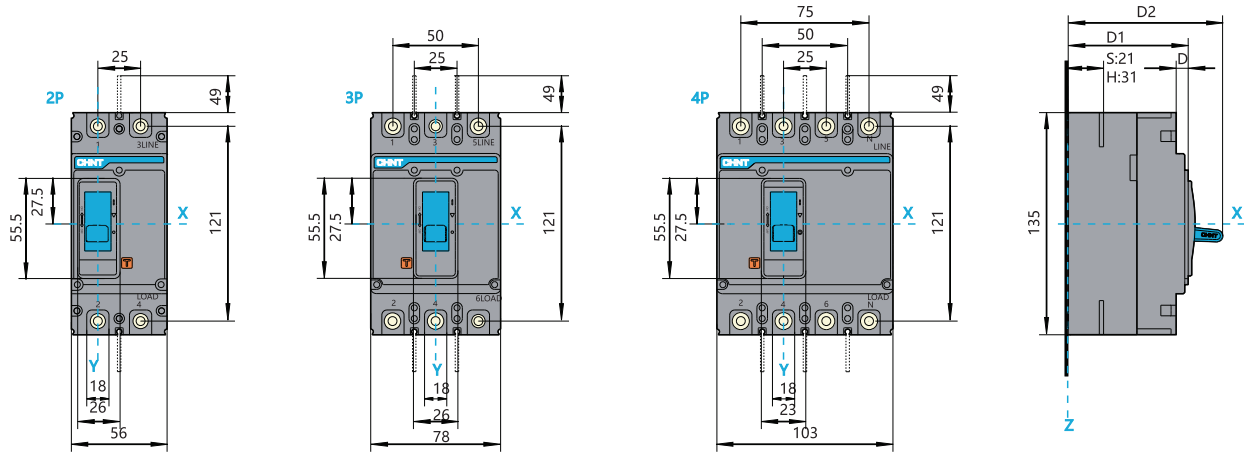

NXMLE-125S/F/H

Front connection, dimension (mm)

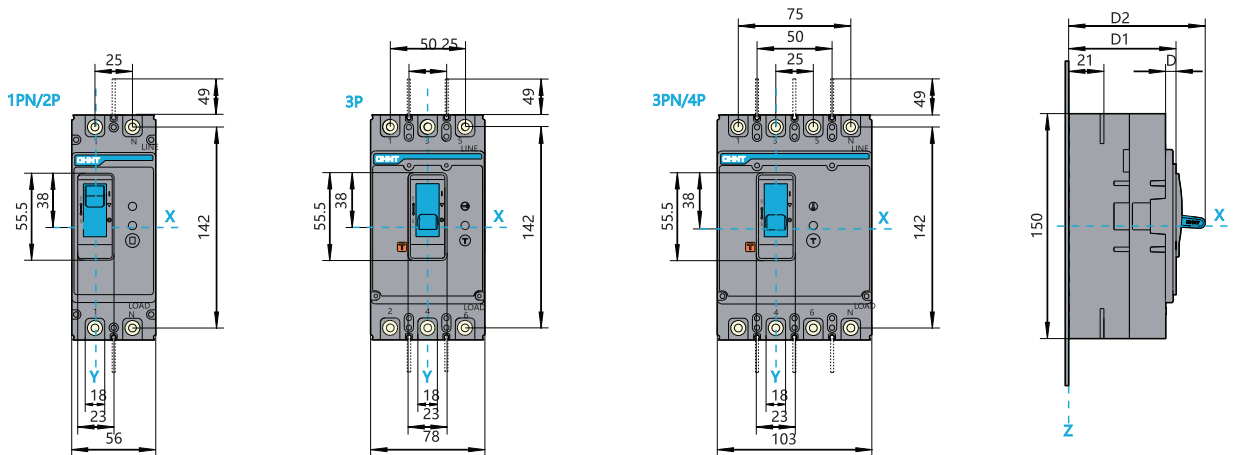

NXM-63E/F/S/H, 125E/F/S/H, NXHM-63,125,NXMLE-125F/S/H

Installation size of baseplate

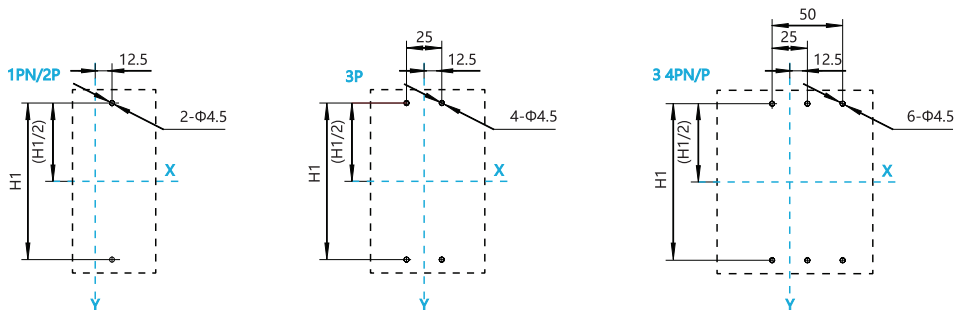

Specification and model	D1	D2	D	H1			Remark
				1PN/2P	3P	3PN/4P	
NXM-63E/S, 125E/S	71	90	7	117	117	117	2P/3P/4P
NXM-63F/H, 125F/H	81	100	7	-	117	117	3P/4P
NXMLE-125S	71	90	7	138	138	138	1PN/2P/3P/3PN/4P
NXMLE-125F/H	81	100	7	-	138	138	3P/3PN/4P
NXHM-63, 125	71	90	7	-	117	117	3P/4P

NXM-63E/S/F/H, 125E/S/F/H, NXMLE-125S/F/H, NXHM-63, 125

Rear connection (mm)

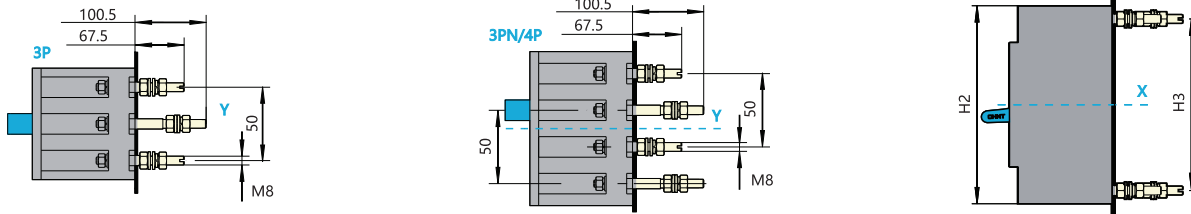

NXM-63E/S/F/H, 125E/S/F/H, NXMLE-125S/F/H, NXHM-63, 125

Rear connection (mm)

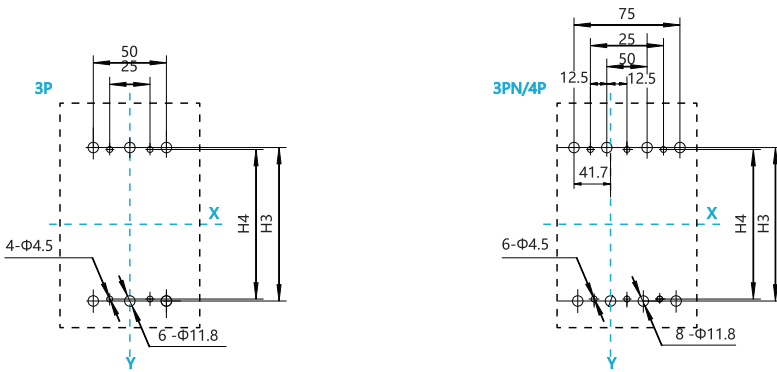

Specification and model	H2	H3	H4	Remark
NXM-63E/S/F/H, 125E/S/F/H	135	121	117	3P/4P
NXMLE-125S/F/H	156	142	138	3P/3PN/4P
NXHM-63, 125	135	121	117	3P/4P

NXM-63E/S/F/H, 125E/S/F/H, NXMLE-125S/F/H, NXHM-63, 125

Plug-in rear connection (mm)

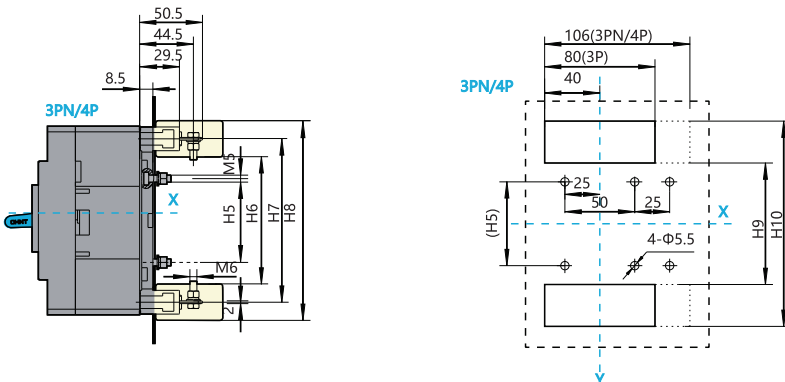

Specification and model	H5	H6	H7	H8	H9	H10	Remark
NXM-63E/S/F/H, 125E/S/F/H	60	75	121	159	92	144	3P/4P
NXMLE-125S/F/H	60	98	142	183	112	165	3P/3PN/4P
NXHM-63, 125	60	75	121	159	92	144	3P/4P



NXM-63E/S/F/H, 125E/S/F/H, NXMLE-125S/F/H, NXHM-63, 125

Cabinet gate hole (small) size (mm)

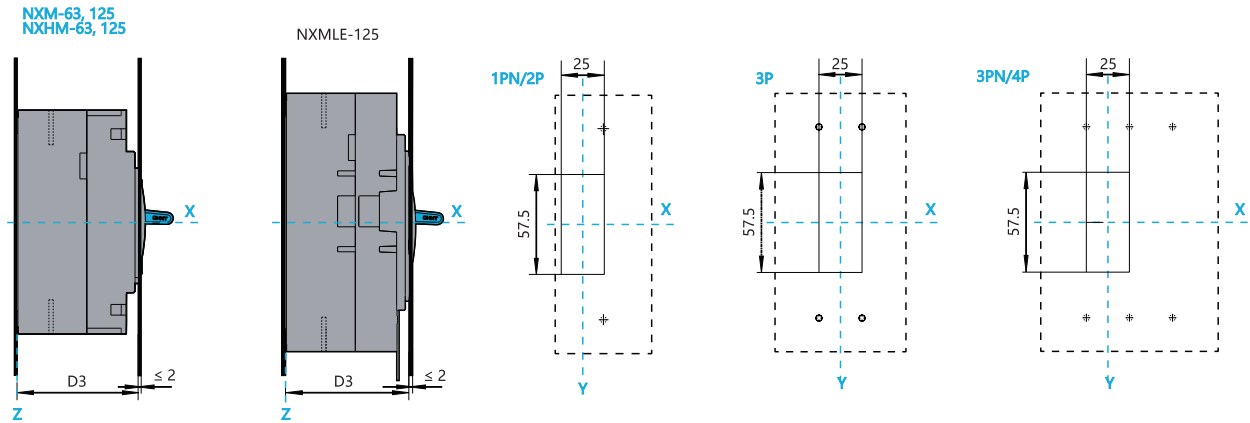

NXM-63E/S/F/H, 125E/S/F/H, NXMLE-125S/F/H, NXHM-63, 125

Cabinet gate hole (large) size (mm)

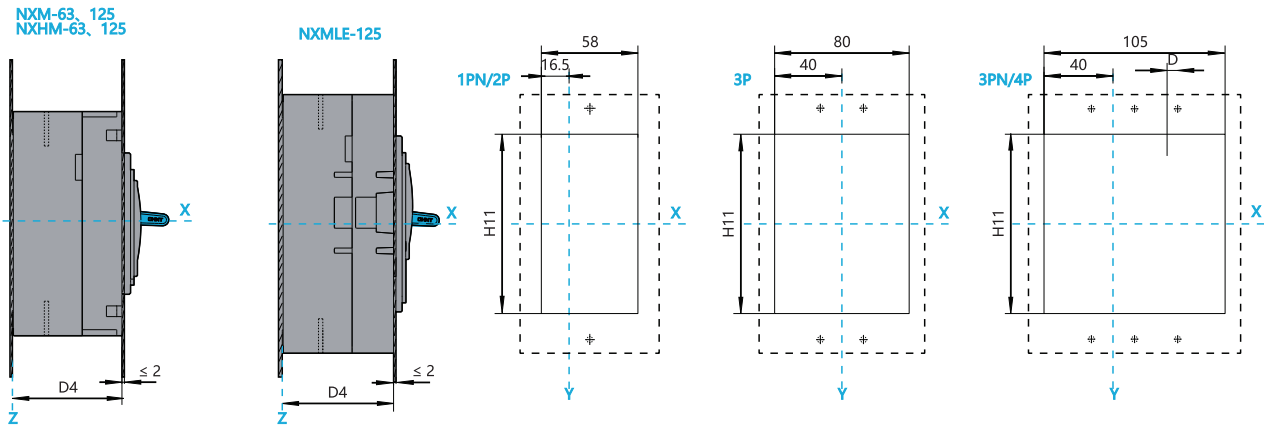

Specification and model	D3	D4	H11		Remark
			3P	3PN/4P	
NXM-63E/S, 125E/S	71.5	64.5	88	88	2P/3P/4P
NXM-63F/H, 125F/H	81.5	74.5	-	88	3P/4P
NXMLE-125S	71	64	110	110	1PN/2P/3P/3PN/4P
NXMLE-125F/H	81	74	-	110	3P/3PN/4P
NXHM-63, 125	71	64	-	87.5	3P/4P

NXM-160E/S/F/H, NXHM-160

Rear connection, dimension (mm)

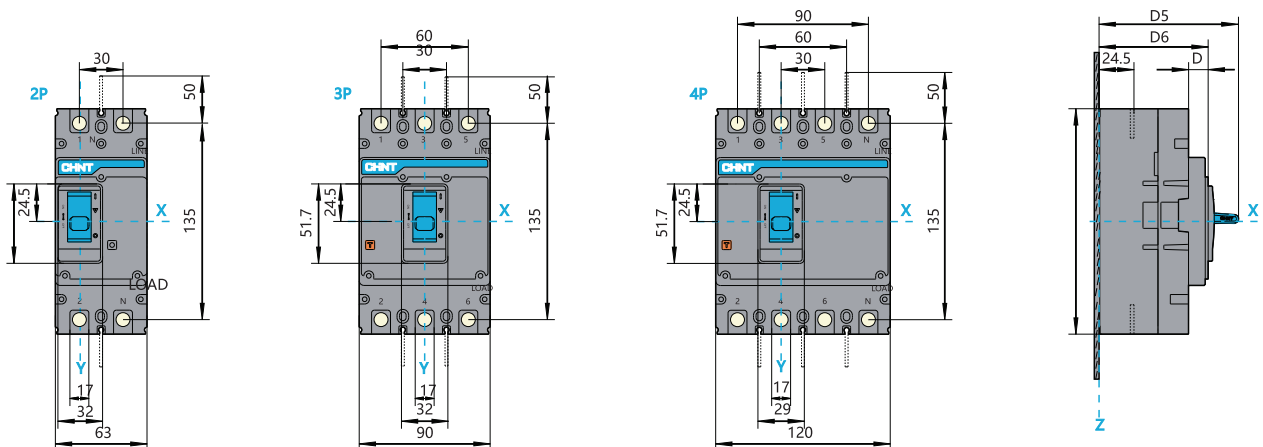

NXMS-160F/H

Front connection, dimension (mm)

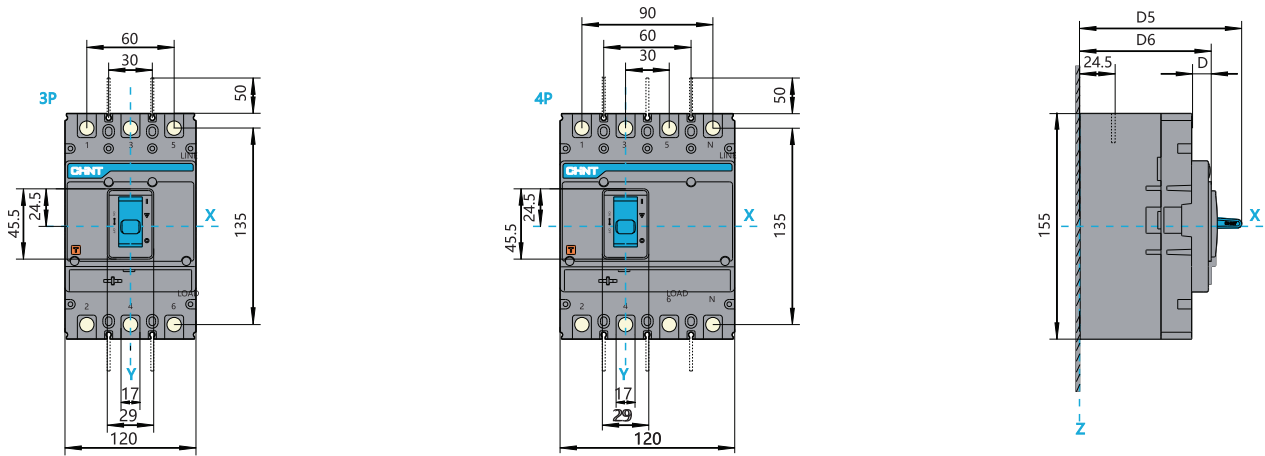

NXMLE-160S/F/H

Front connection, dimension (mm)

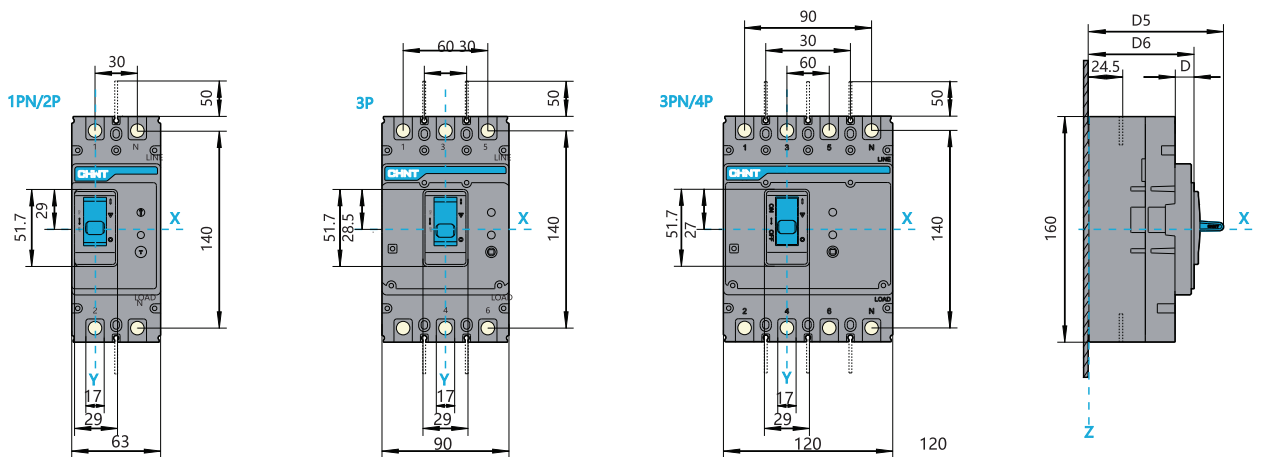

NXM-160E/S/F/H, NXMS-160F/H, NXMLE-160S/F/H, NXHM-160

Installation size of baseplate (mm)

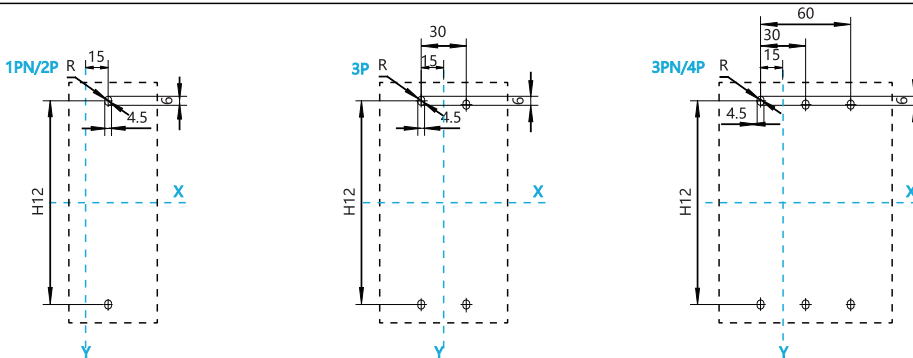

Specification and model	D6	D5	D	H12			Remark
				1PN/2P	3P	3PN/4P	
NXM-160E/S	75.5	96	13.5	130.5	130.5	130.5	2P/3P/4P
NXM-160F/H	91	112	13.5	-	130.5	130.5	3P/4P
NXMS-160F/H	91	112	13.5	130.5	130.5	130.5	3P/4P
NXMLE-160S	75.5	96	13.5	135.5	135.5	135.5	1PN/2P/3P/3PN/4P
NXMLE-160F/H	91	112	13.5	-	135.5	135.5	3P/3PN/4P
NXHM-160	75.5	96	13.5	-	130.5	130.5	3P/4P



NXM-160E/S/F/H, NXMS-160F/H, NXMLE-160S/F/H, NXHM-160

Rear connection, dimension (mm)

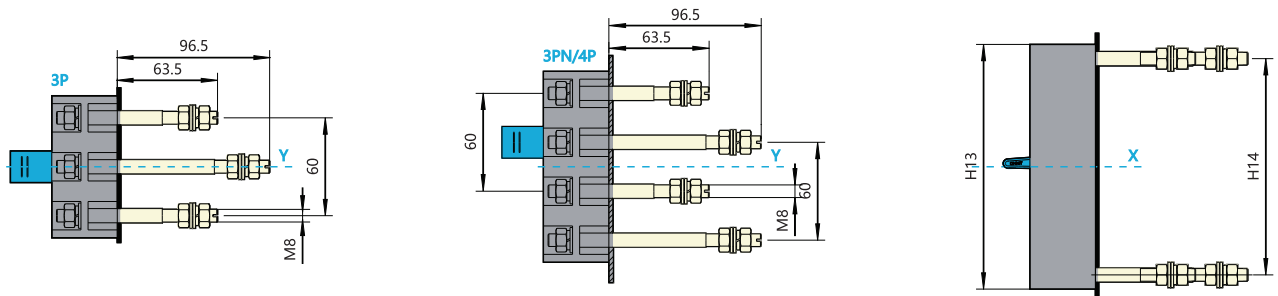

NXM-160E/S/F/H, NXMS-160F/H, NXMLE-160S/F/H, NXHM-160

Plug-in rear connection, dimension (mm)

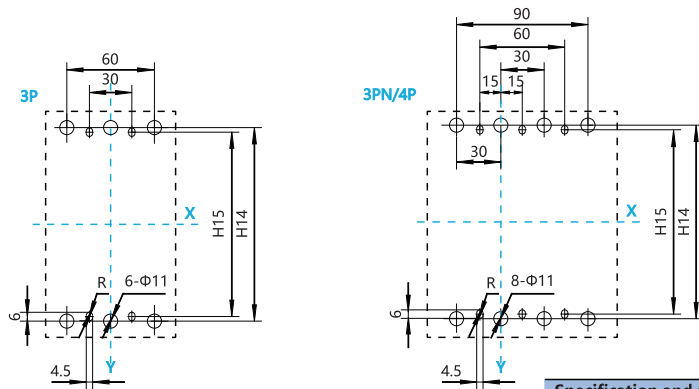

Specification and model	H13	H14	H15	Remark
NXM-160E/S/F/H	155	135	130.5	3P/4P
NXMS-160F/H	155	135	130.5	3P/4P
NXMLE-160S/F/H	160	140	135.5	3P/3PN/4P
NXHM-160	155	135	130.5	3P/4P

NXM-160E/S/F/H, NXMS-160F/H, NXMLE-160S/F/H, NXHM-160

Plug-in back-panel wiring, outline and installation size (mm)

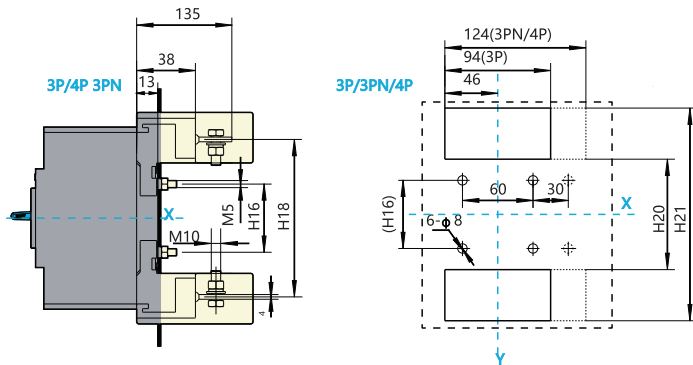

Specification and model	H16	H18	H20	H21	Remark
NXM-160E/S/F/H	72	135	106	167	3P/4P
NXMS-160F/H	72	135	106	167	3P/4P
NXMLE-160S/F/H	77	140	111	172	3P/3PN/4P
NXHM-160	72	135	106	167	3P/4P

NXM-160E/S/F/H, NXMS-160F/H, NXMLE-160S/F/H, NXHM-160

Cabinet gate hole (small) size (mm)

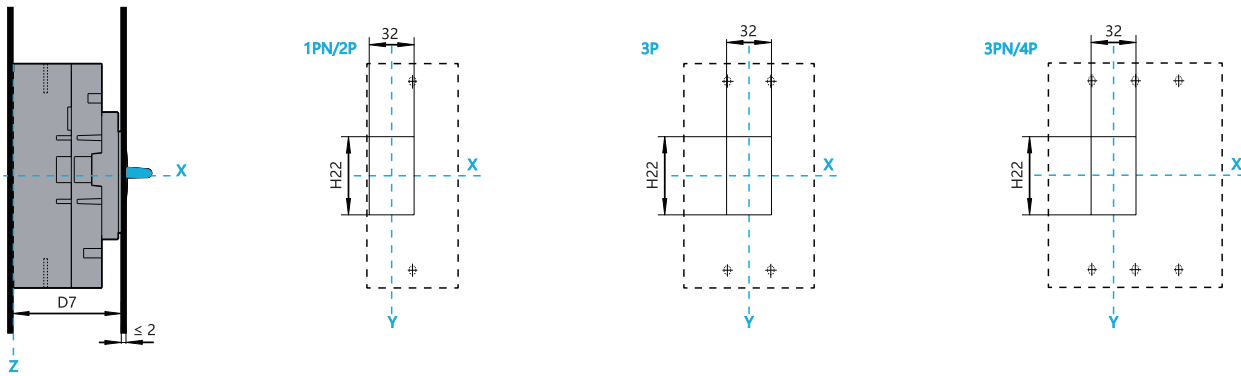

NXM-160E/S/F/H, NXMS-160F/H, NXMLE-160S/F/H, NXHM-160

Cabinet gate hole (large) size (mm)

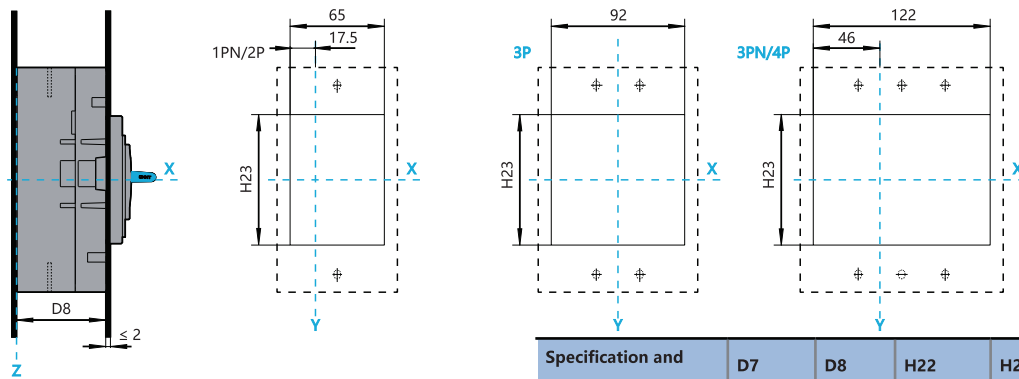

Specification and model	D7	D8	H22	H23	Remark
NXM-160E/S	75.5	62	54	90	2P/3P/4P
NXM-160F/H	91	77.5	54	90	3P/4P
NXMS-160F/H	91	77.5	54	92	3P/4P
NXMLE-160S	75.5	62	54	95	1PN/2P/3P/3PN/4P
NXMLE-160F/H	91	77.5	54	95	3P/3PN/4P
NXHM-160	75.5	62	54	90	3P/4P

NXM-250E/S/F/H, NXHM-250

Front connection, dimension (mm)

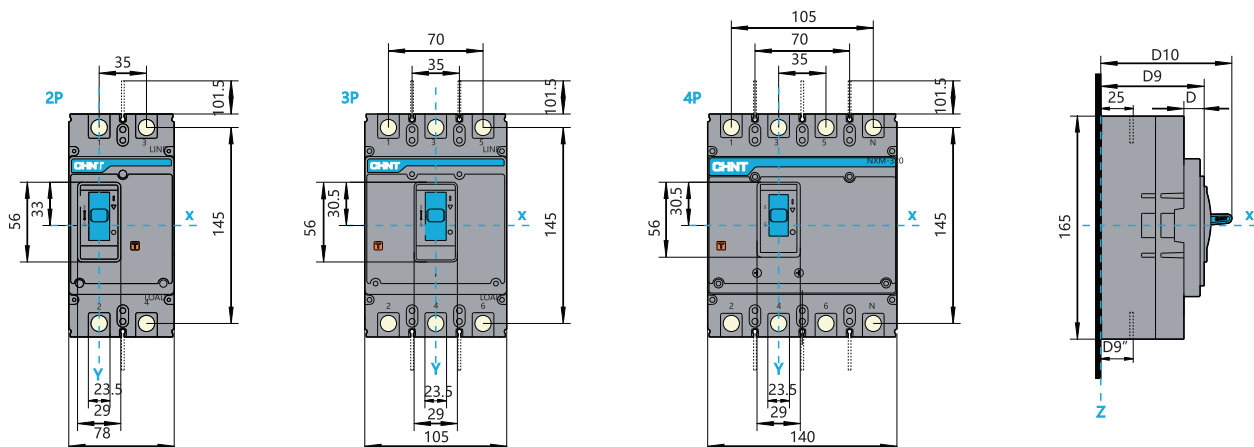

NXMS-250F/H

Front connection, dimension (mm)

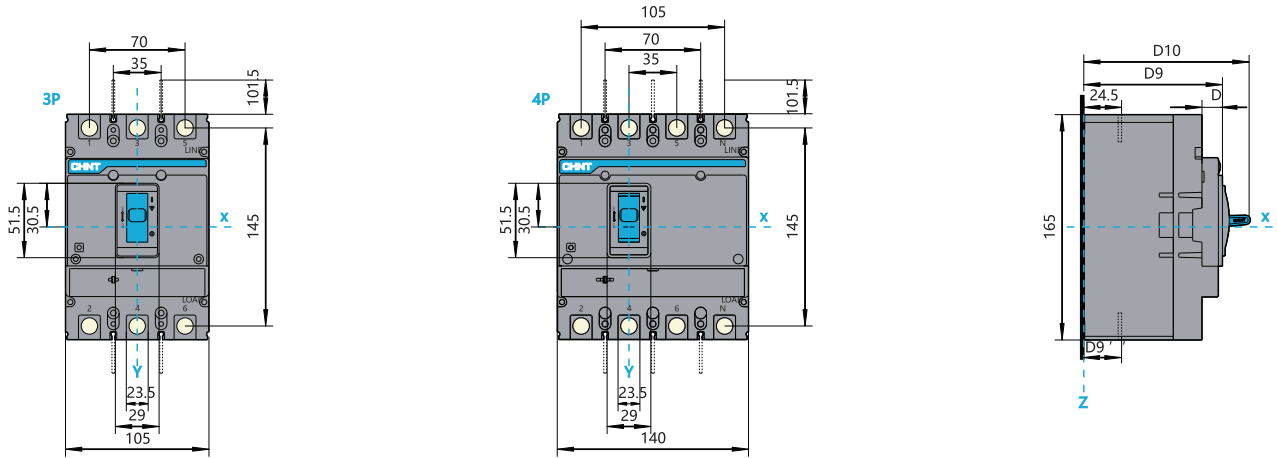

NXMLE-250S/F/H

Front connection, dimension (mm)

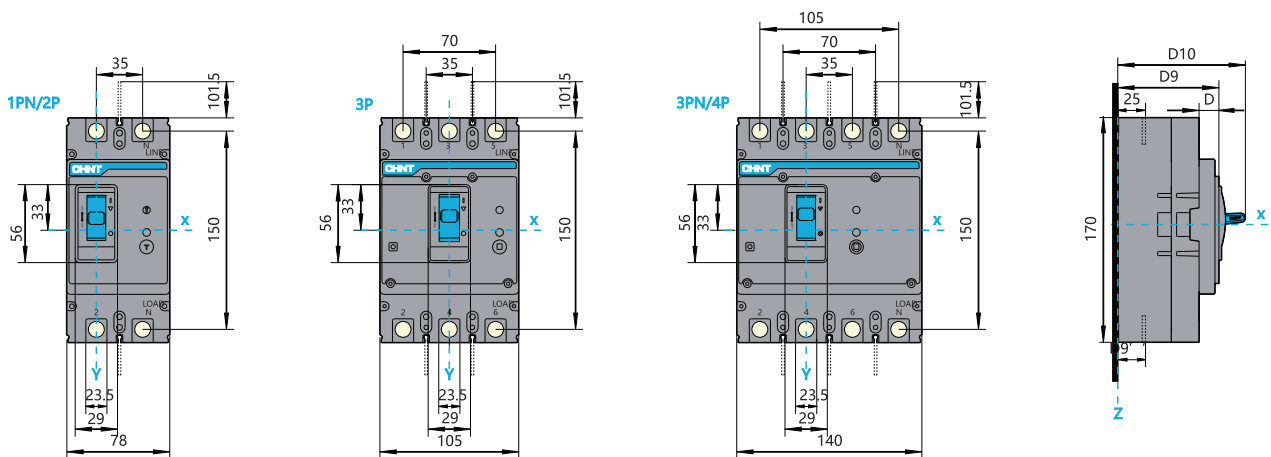

NXM-250E/S/F/H, NXMS-250F/H, NXMLE-250S/F/H, NXHM-250

Front-panel wiring, installation size (mm)

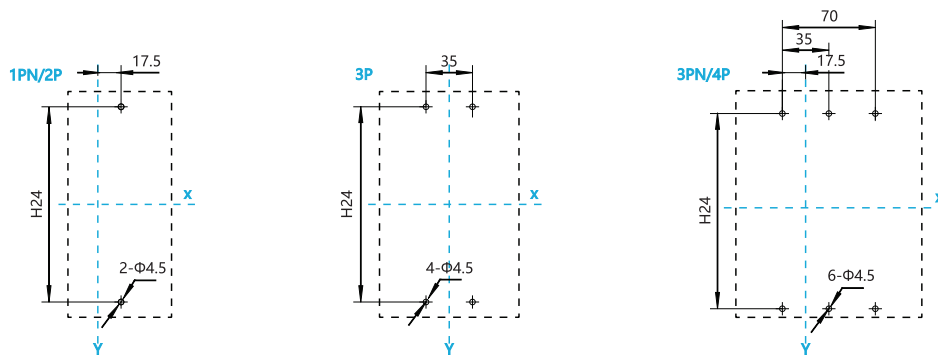

Specification and model	D9	D9"			D10	D	H24			Remark	
		125/160A	180/200A	225/250A			1PN/2P	3P	3PN/4P		
NXM-250E/S	77	22.8	23	23	98	15	126	126	126	2P/3P/4P	98
NXM-250F/H	102	23	23.5	24	123	15	-	126	126	3P/4P	123
NXMS-250F/H	102	25	24		123	15	-	126	126	3P/4P	123
NXMLE-250S	77	25	24.5		99	15	131	131	131	1PN/2P/3PN/4P	98
NXMLE-250F/H	80	28	27.5		102	15	-	131	131	3P/3PN/4P	101
NXHM-250	77	25	24		98	15	-	126	126	3P/4P	122

NXM-250E/S/F/H, NXMS-250F/H, NXMLE-250S/F/H, NXHM-250, 320

Installation size of baseplate (mm)

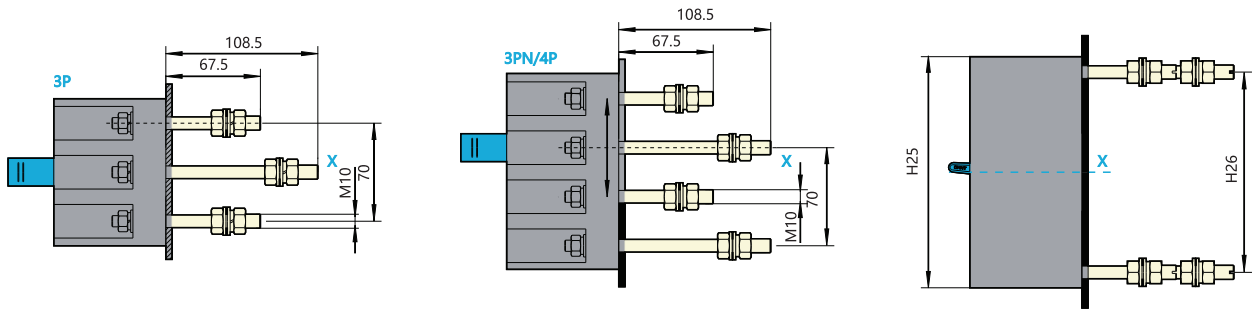

NXM-250E/S/F/H, NXMS-250F/H, NXMLE-250S/F/H, NXHM-250, 320

Installation size of baseplate (mm)

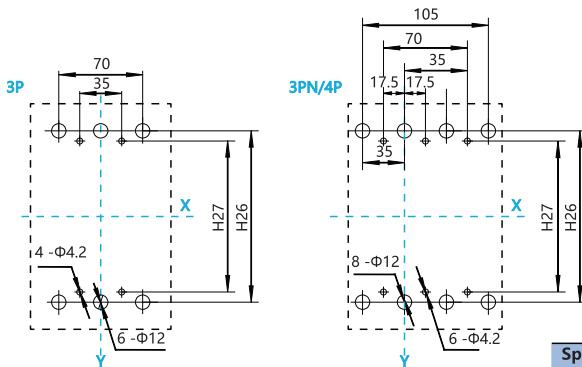

Specification and model	H25	H26	H27	Remark
NXM-250E/S/F/H	165	145	126	3P/4P
NXMS-250F/H	165	145	126	3P/4P
NXMLE-250S/F/H	170	150	131	3P/3PN/4P
NXHM-250, 320	165	145	126	3P/4P

NXM-250E/S/F/H, NXMS-250F/H, NXMLE-250S/F/H, NXHM-250, 320

Plug-in rear connection, dimension (mm)

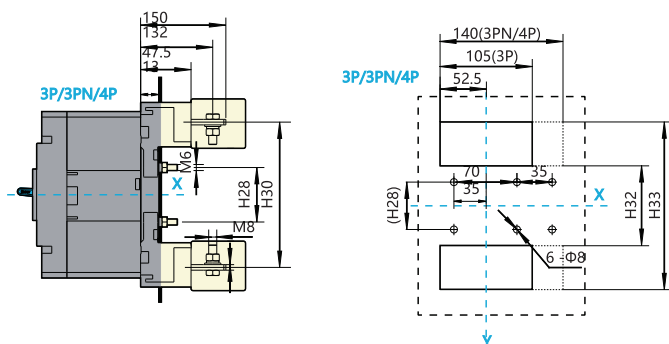

Specification and model	H28	H30	H32	H33	Remark
NXM-250E/S/F/H	74	145	108	180	3P/4P
NXMS-250F/H	74	145	108	180	3P/4P
NXMLE-250S/F/H	79	144	113	185	3P/3PN/4P
NXHM-250, 320	74	139	108	180	3P/4P

NXM-250E/S/F/H, NXMS-250F/H, NXMLE-250S/F/H, NXHM-250, 320

Cabinet gate hole (small size) (mm)

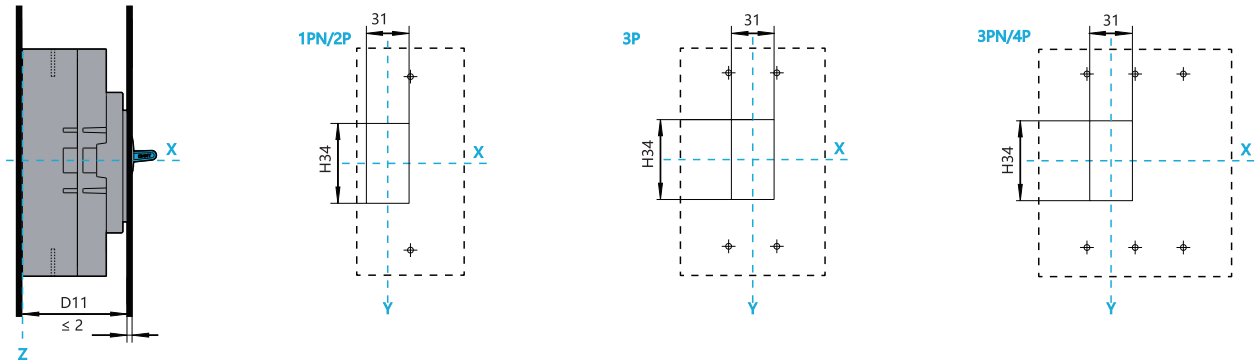

NXM-250E/S/F/H, NXMS-250F/H, NXMLE-250S/F/H, NXHM-250, 320

Cabinet gate hole (large size) (mm)

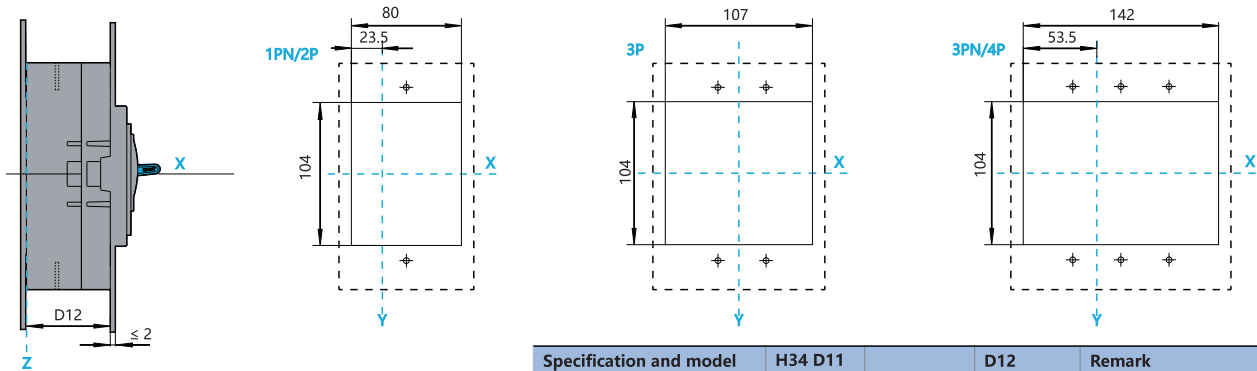

Specification and model	H34	D11	D12	Remark
NXM-250E/S	58	77.5	62.8	2P/3P/4P
NXM-250F/H	58	102.5	87.8	3P/4P
NXMS-250F/H	53.5	102.5	87.8	3P/4P
NXMLE-250S	58	77.5	62.8	1PN/2P/3P/3PN/4P
NXMLE-250F/H	58	80.5	65.5	3P/3PN/4P
NXHM-250, 320	58	77.5	62.8	3P/4P

NXM-400E/S/F/H, 630E/S/F/H, NXHM-400, 630

Front connection, dimension (mm)

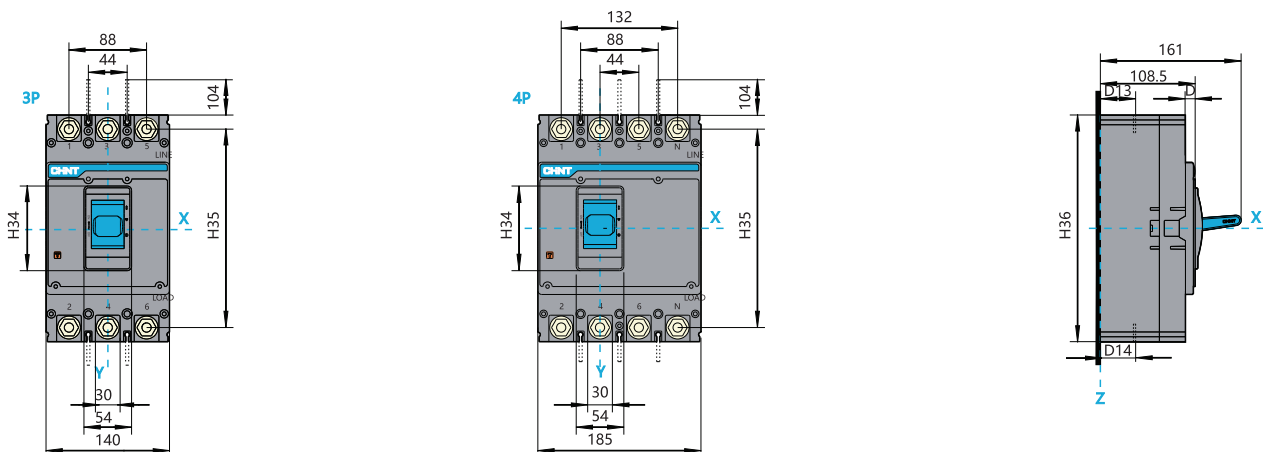

NXMS-400S/F/H, 630S/F/H

Front connection, dimension (mm)

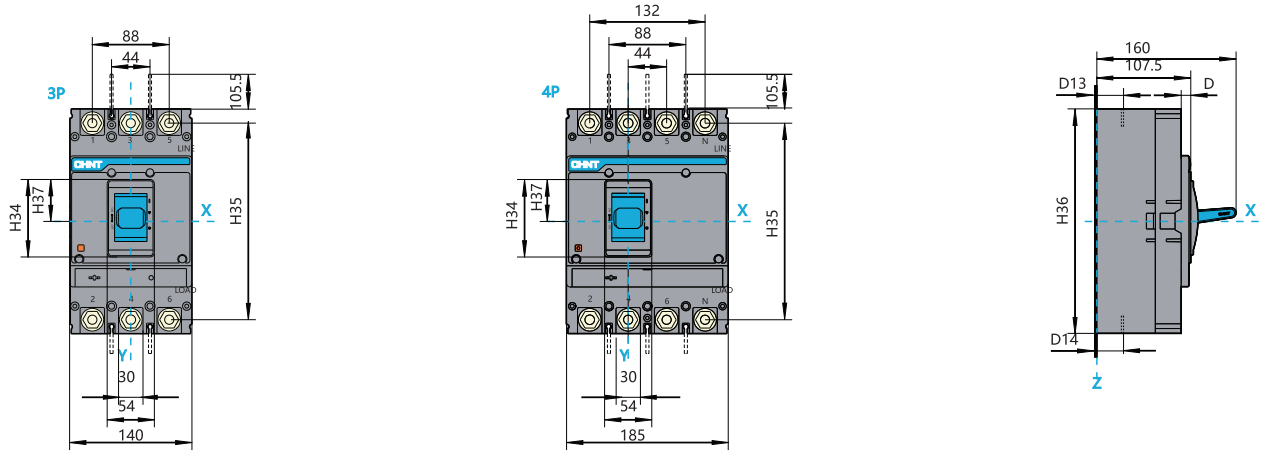

NXMLE-400S/F/H, 630S/F/H

Front connection, dimension (mm)

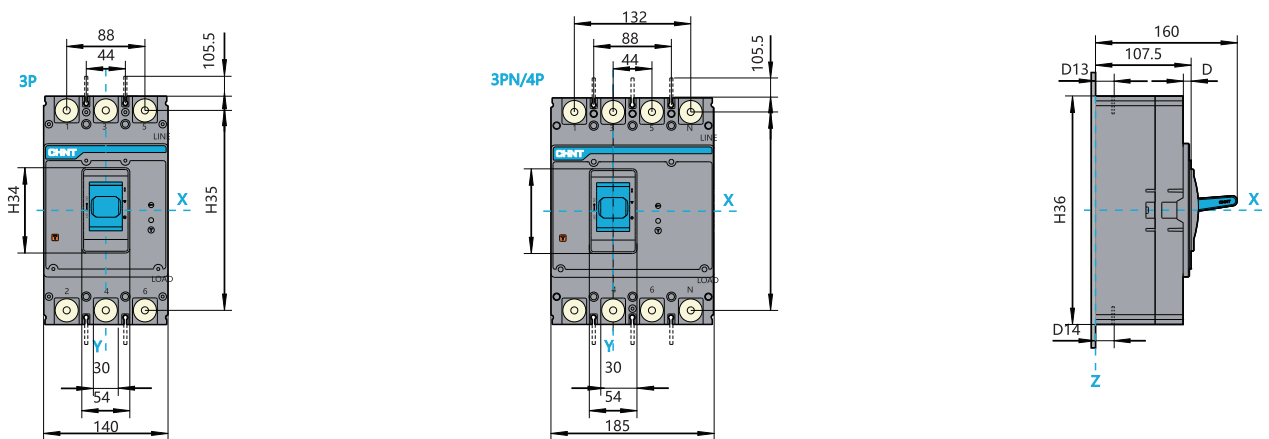

NXM-400E/S/F/H, 630E/S/F/H, NXMS-400E/F/H, 630E/F/H, NXMLE-400S/F/H, 630S/F/H, NXHM-400, 630

Installation size of baseplate (mm)

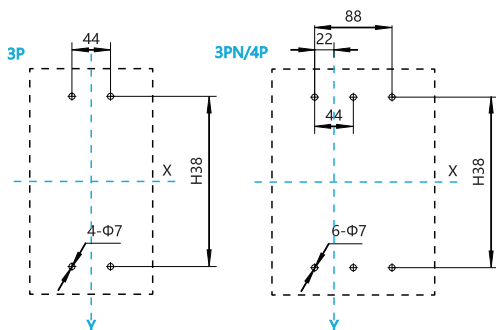

Specification and model	H34	H35	H36	H37	H38	D13	D14	D	Remark
NXM-400E/S/F/H NXM-630E/S/F/H	92	225	257	46	194	39.5	37.5	11	250A-280A
						40.5	38		300A-315A-320A
						39	39		350A-380A
						41.5	39		400A-450A
						40.5	40.5		500A-550A 600A-630A
NXMS-400S/F/H NXMS-630S/F/H	89	225	257	48	194	40	37.5	11	400A
						39.5	41		630A
						39	38.5		250A-280A
NXMLE-400S/F/H NXMLE-630S/F/H	92	235	267	51	228	39.5	39.5	11	300A-315A-320A
						40.5	39.5		350A-380A
						39.5	39.5		400A-450A
						41.5	39		500A-550A
						40.5	40.5		600A-630A
NXHM-400 NXHM-630	92	225	257	46	194	40.5	39	11	400A
						41.5	40.5		630A

NXM-400E/S/F/H, 630E/S/F/H, NXMS-400E/F/H, 630E/F/H, NXMLE-400S/F/H, 630S/F/H, NXHM-400, 630

Rear connection, dimension (mm)

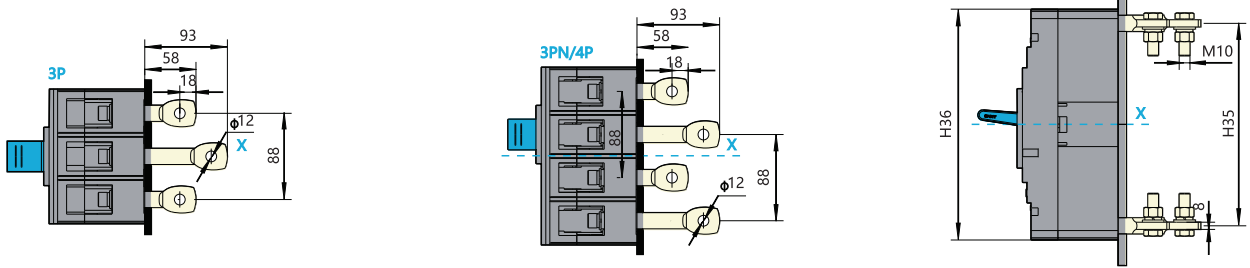

NXM-400E/S/F/H, 630E/S/F/H, NXMS-400E/F/H, 630E/F/H, NXMLE-400S/F/H, 630S/F/H, NXHM-400, 630

Installation size of baseplate (mm)

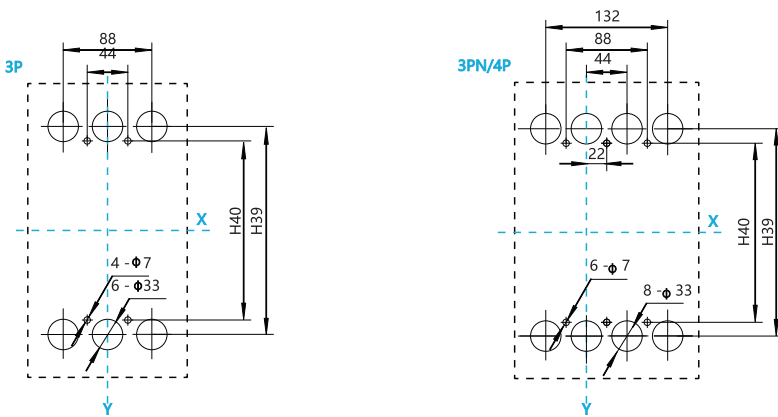

Specification and model	H39	H40	Remark
NXM-400E/S/F/H, 630E/S/F/H	225	194	3P/4P
NXMS-400S/F/H, 630S/F/H	225	194	3P/4P
NXMLE-400S/F/H	235	228	3P/3PN/4P
NXMLE-630S/F/H	235	228	3P/3PN/4P
NXHM-400, 630	225	194	3P/4P

NXM- 400E/S/F/H, 630E/S/F/H, NXMS-400E/F/H, 630E/F/H, NXMLE-400S/F/H, 630S/F/H, NXHM-400, 630

Plug-in rear connection, dimension (mm)

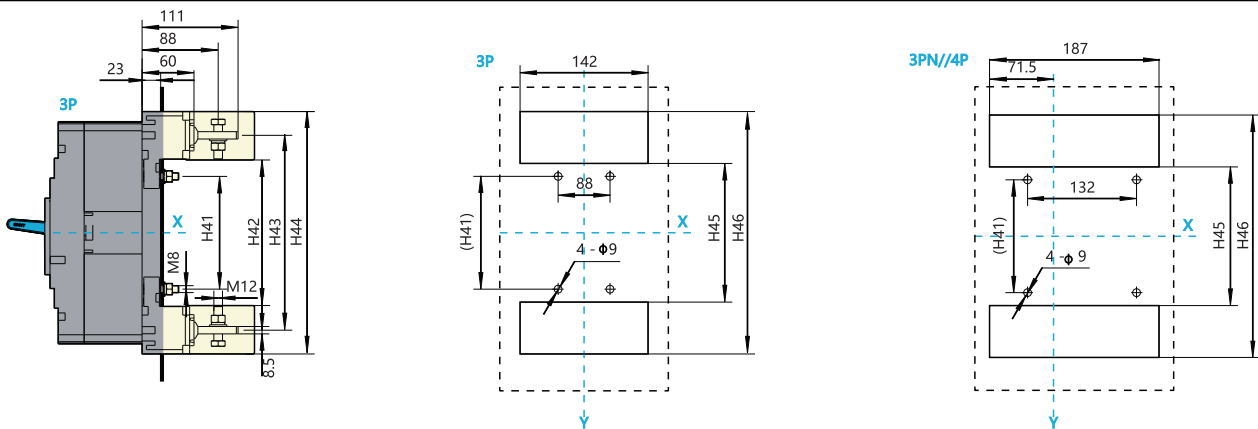

Specification and model	H41	H42	H43	H44	H45	H46	Remark
NXM-400E/S/F/H, 630E/S/F/H	145	171	225	281	168	283	3P/4P
NXMS-400S/F/H, 630S/F/H	145	171	225	281	168	283	3P/4P
NXMLE-400S/F/H	155	181	235	291	178	293	3P/3PN/4P
NXMLE-630S/F/H	155	181	235	291	178	293	3P/3PN/4P
NXHM-400, 630	145	171	225	281	168	283	3P/4P

NXM-400E/S/F/H, 630E/S/F/H, NXMS-400E/F/H, 630E/F/H, NXMLE-400S/F/H, 630S/F/H, NXHM-400, 630

Cabinet gate hole (small) size (mm)

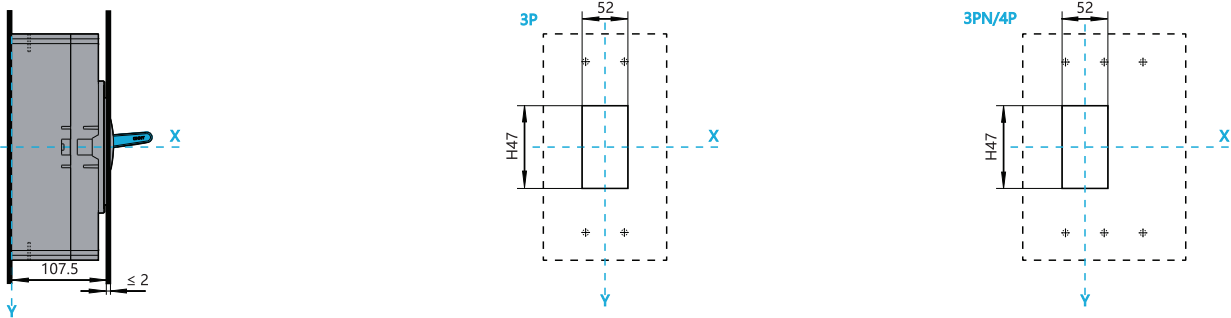

NXM-400E/S/F/H, 630E/S/F/H, NXMS-400E/F/H, 630E/F/H, NXMLE-400S/F/H, 630S/F/H, NXHM-400, 630

Cabinet gate hole (large) size (mm)

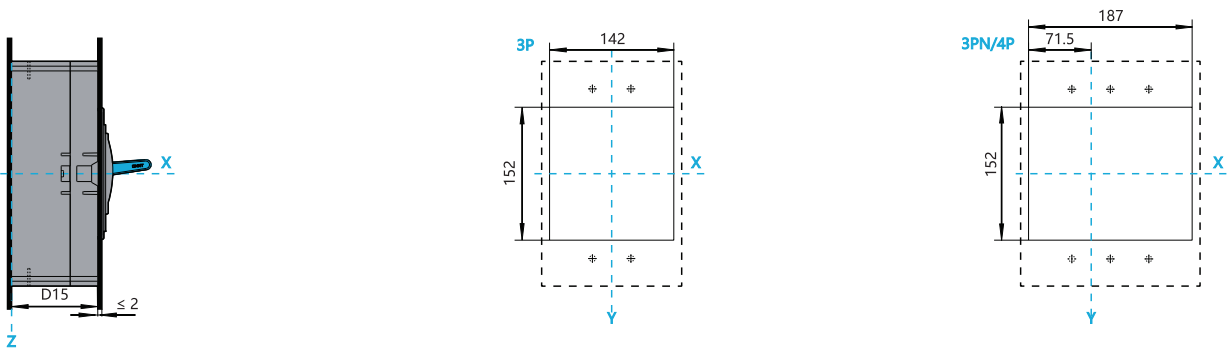

Specification and model	H47	D15	Remark
NXM-400E/S/F/H, 630E/S/F/H	94	96.5	3P/4P
NXMS-400S/F/H, 630S/F/H	87	96.5	3P/4P
NXMLE-400S/F/H, 630S/F/H	94	98.5	3P/3PN/4P
NXHM-400, 630	94	96.5	3P/4P

NXM-800S/F/H, NXHM-800

Front connection, dimension (mm)

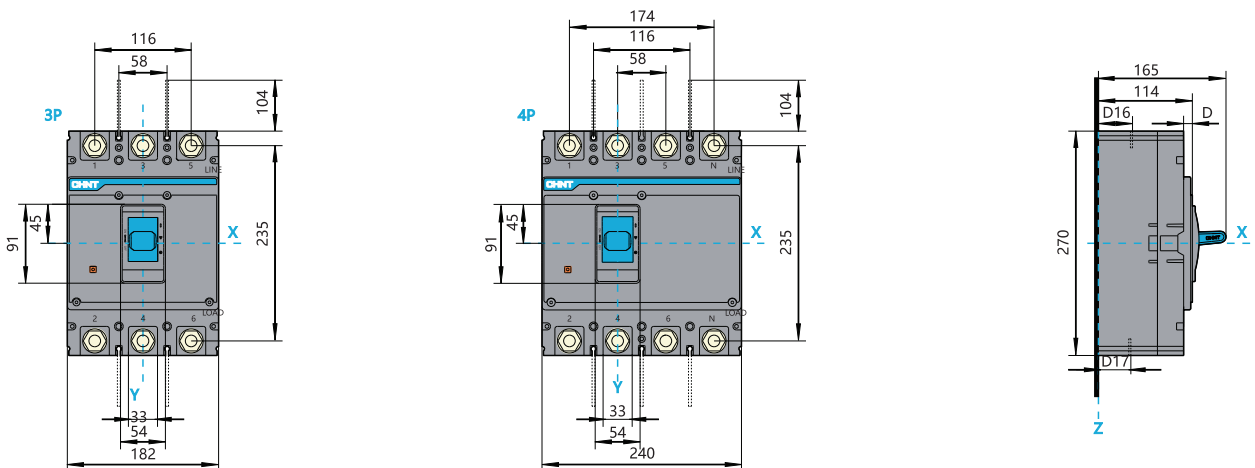

NXM-800S/F/H, NXHM-800

Installation size of baseplate(mm)

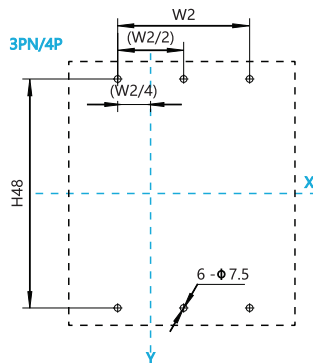
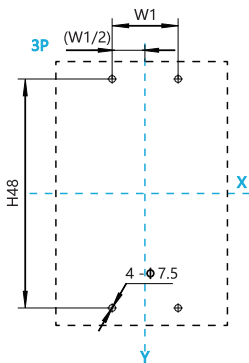

Specification and model	D16	D17	D	H48	W1	W2	Remark
NXM-800S/F/H NXHM-800	43	41	10.5	200	58	116	630A
	44	42	10.5	200	58	116	700A
	45	43	10.5	200	58	116	800A

NXM-800S/F/H, NXHM-800

Rear connection, dimension (mm)

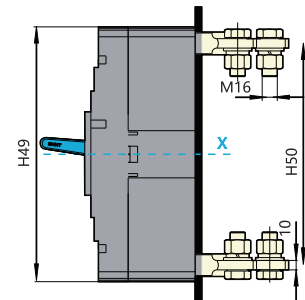
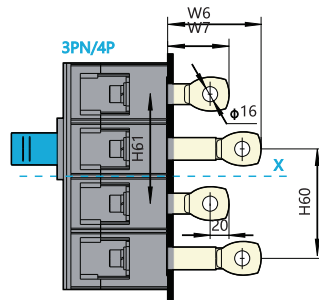
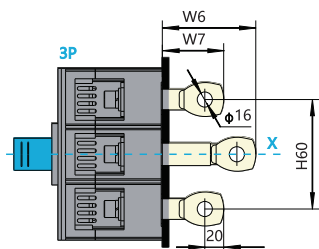

NXM-800S/F/H, NXHM-800

Rear connection, dimension(mm)

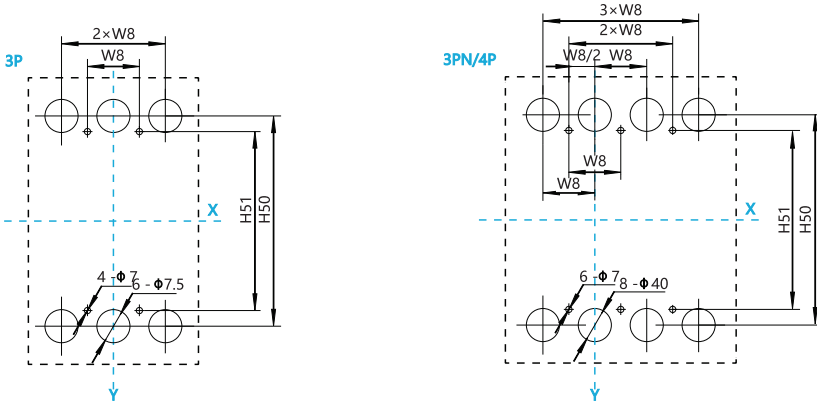

Specification and model	W6	W7	W8	H49	H50	H51	H60
NXM-800S/F/H	99	66	58	270	235	200	116
NXHM-800	99	66	58	270	235	200	116

NXM-800S/F/H, NXHM-800

Plug-in rear connection, dimension (mm)

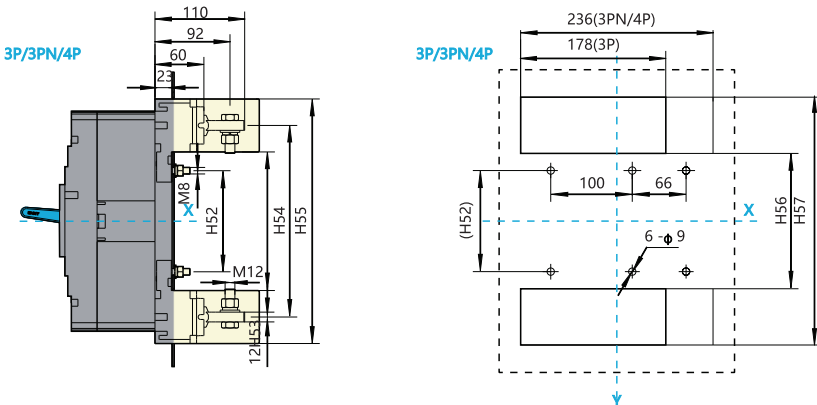

Specification and model	H52	H53	H54	H55	H56	H57	Remark
NXM-800S/F/H	124	170	235	300	168	302	3P/4P
NXHM-800	124	170	235	300	168	302	3P/4P

NXM-800S/F/H, NXHM-800

Cabinet gate hole (small) size (mm)

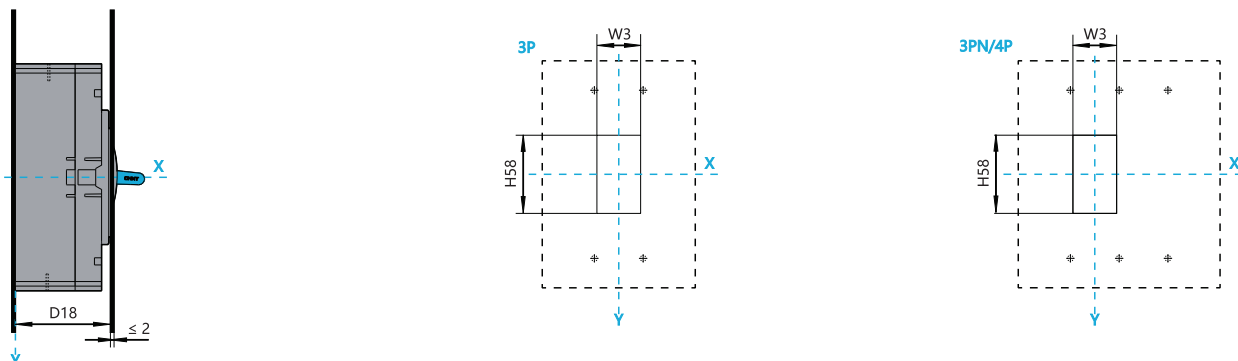

NXM-800S/F/H, NXHM-800

Cabinet gate hole (large size) (mm)

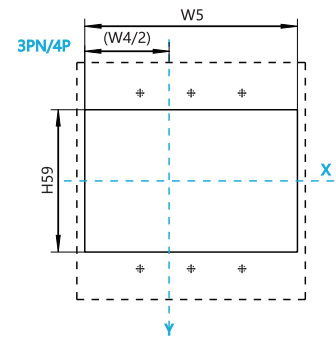
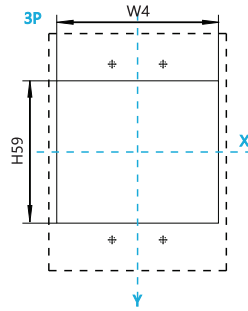
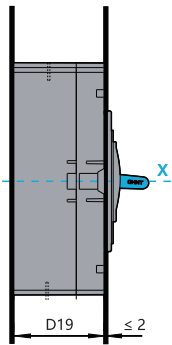

Specification and model	D18	D19	H58	W3	H59	W4	W5	Remark
NXM-800S/F/H	114.5	104	93	52	162	184	242	3P/4P
NXHM-800	114.5	104	93	52	162	184	242	3P/4P



NXM-1000S/H, NXHM-1000

Front connection, dimension (mm)

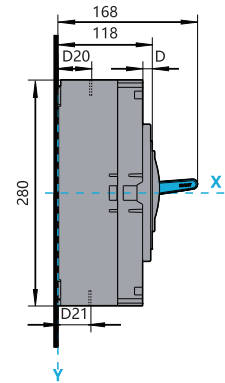
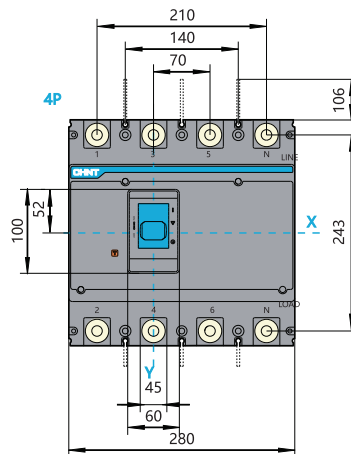
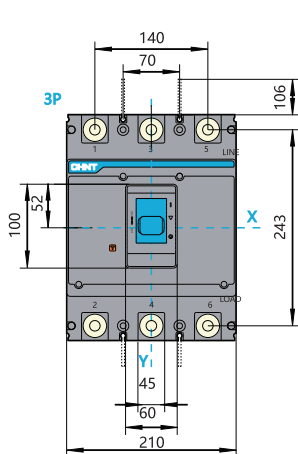

NXMS-1000S/H

Front connection, dimension (mm)

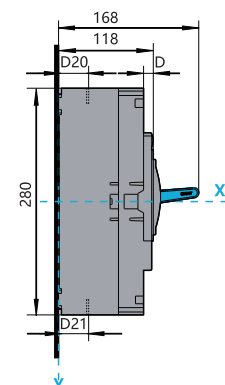
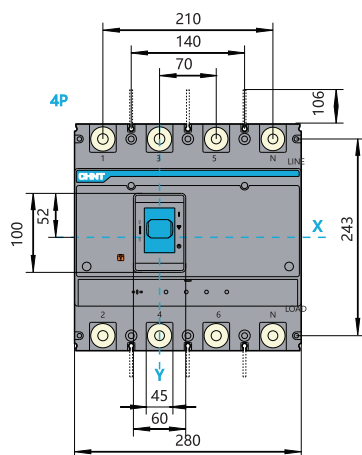
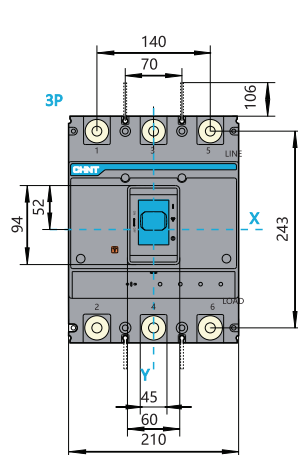

NXM-1000S/H, NXMS-1000S/H, NXHM-1000

Installation size of baseplate (mm)

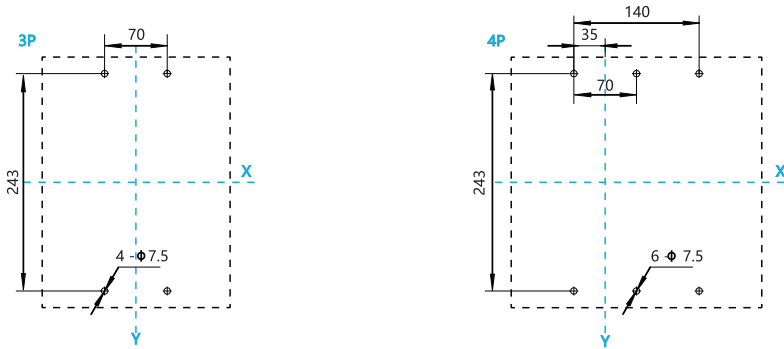

Specification and model	D20	D21	D	Remark
NXM-1000S/H	41	41	12	800A
NXHM-1000	43	42	12	1000A
NXMS-1000S/H	43	43	12	800/1000A

NXM-1000S/H, NXMS-1000S/H, NXHM-1000

Rear connection, dimension (mm)

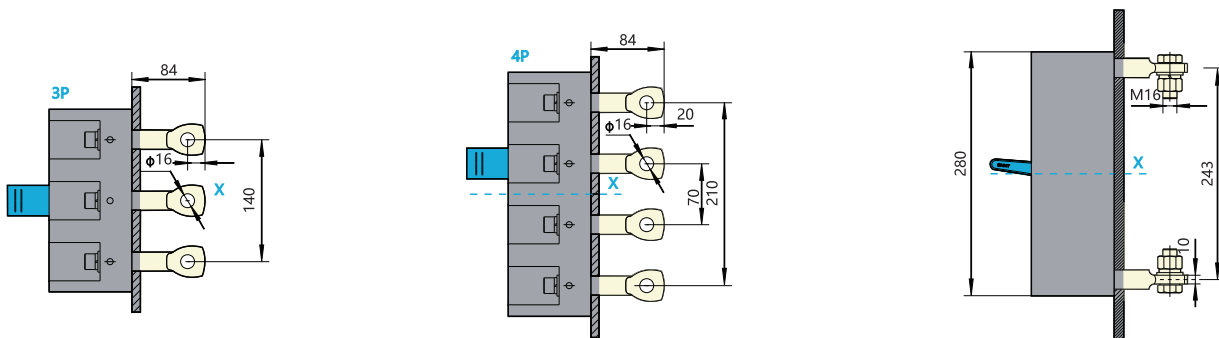

NXM-1000S/H, NXMS-1000S/H, NXHM-1000

Rear connection, dimension (mm)

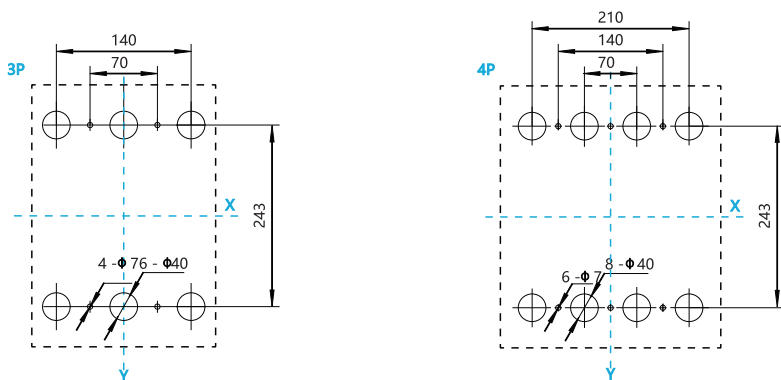



NXM-1000S/H, NXMS-1000S/H, NXHM-1000

Plug-in rear connection, dimension (mm)

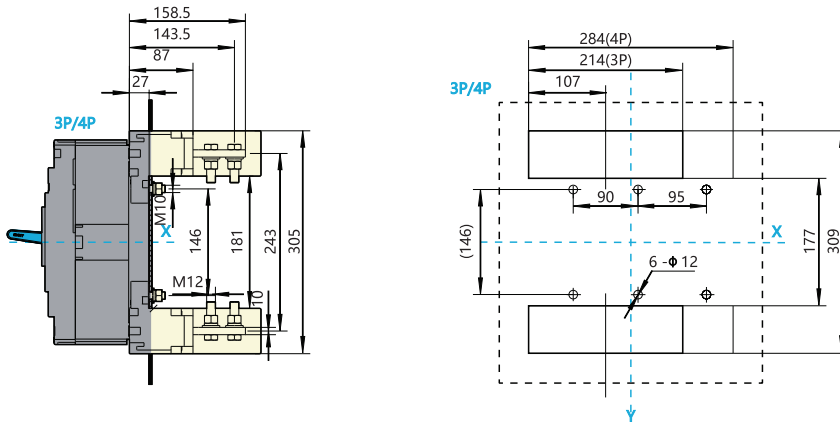

NXM-1000S/H, NXMS-1000S/H NXHM-1000

Cabinet gate hole (small) size (mm)

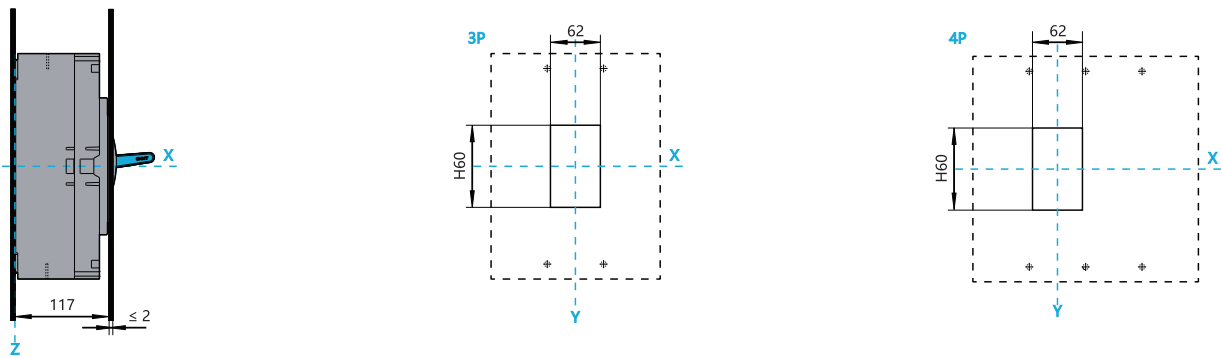

NXM-1000S/H, NXMS-1000S/H NXHM-1000

Cabinet gate hole (large) size (mm)

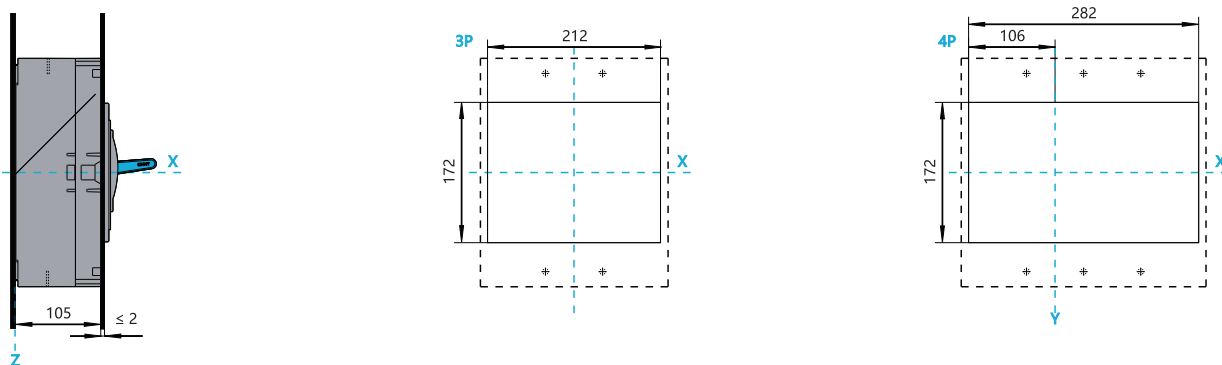

Specification and model	H60	Remark
NXM-1000S/H	102	3P/4P
NXMS-1000S/H	95	3P/4P
NXHM-1000	102	3P/4P

NXM-1250S/H,1600S/H

Front connection, dimension (mm)

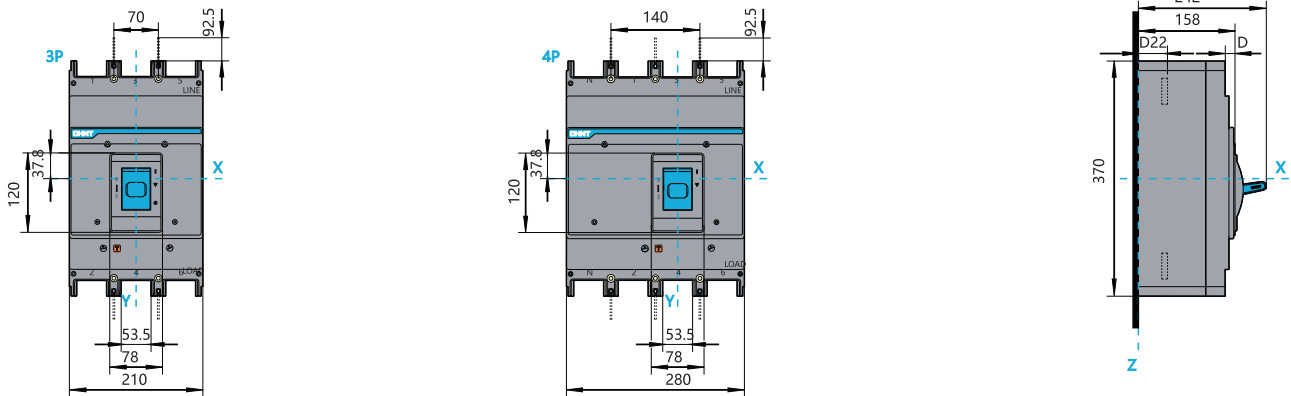

NXMS-1250S/H,1600S/H

Front connection, dimension (mm)

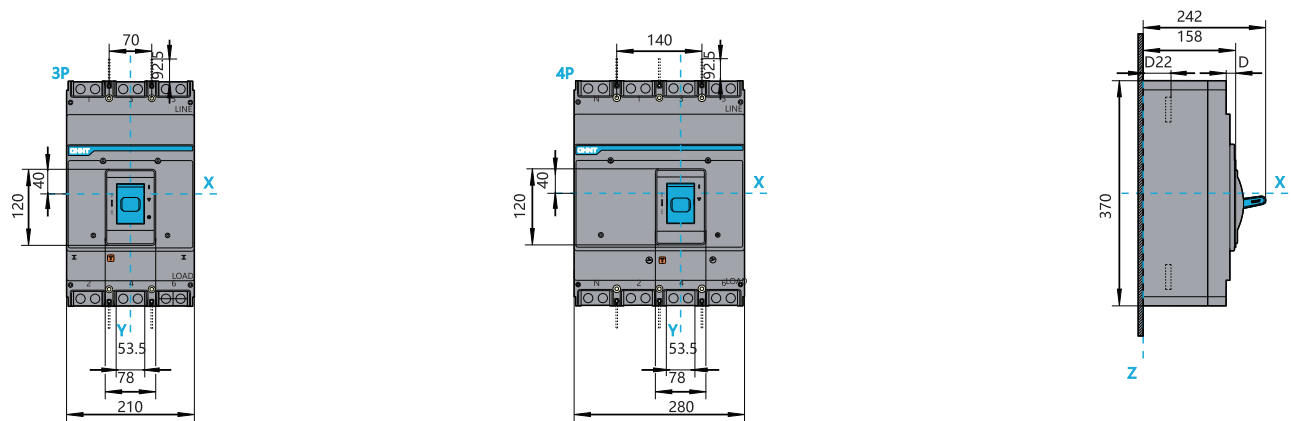

NXM-1250S/H,1600S/H, NXMS-1250S/H,1600S/H

Installation size of baseplate (mm)

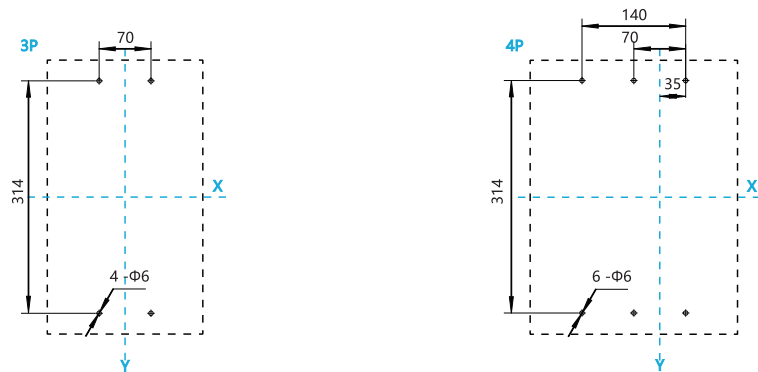

Specification and model	D22	D	Remark
NXM-1250S/H,1600S/H	55	15.5	1000A
	57		1250A
	65		1600A
NXMS-1250S/H,1600S/H	57	15.5	1250A
	65		1600A

NXM-1250S/H, 1600S/H, NXMS-1250S/H, 1600S/H

Cabinet gate hole (small) size (mm)

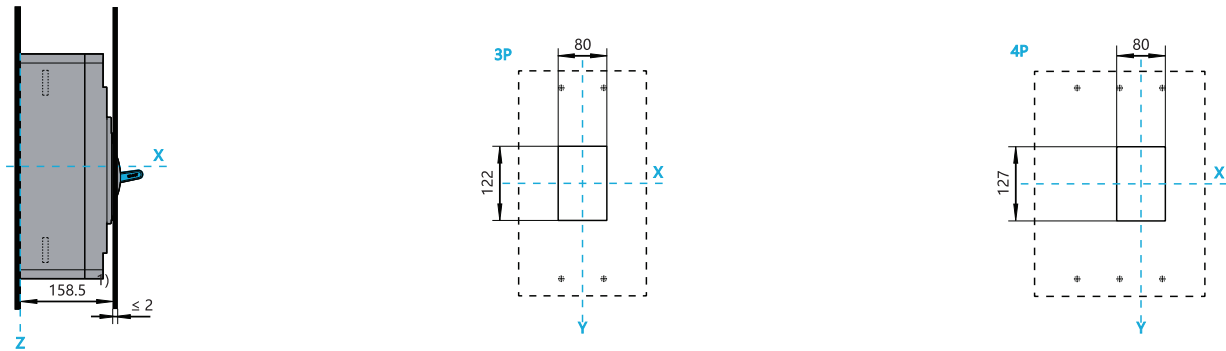

NXM-1600S/H, NXMS-1600S/H, NXHM-1600

Cabinet gate hole (large) size (mm)

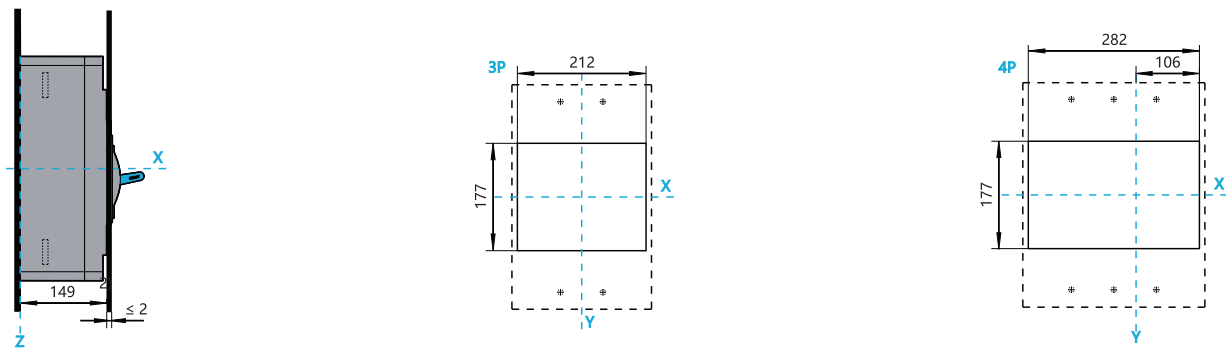

NXM-63

Tripping curve

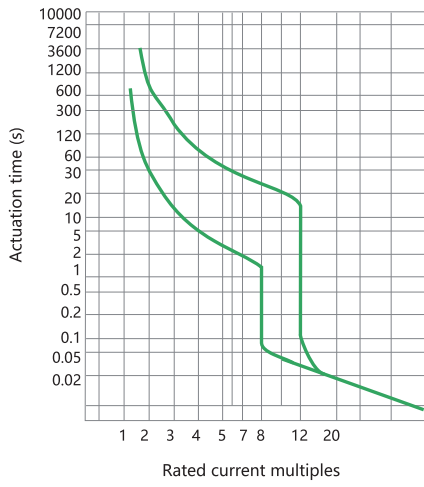

NXM-63

Temperature compensation curve

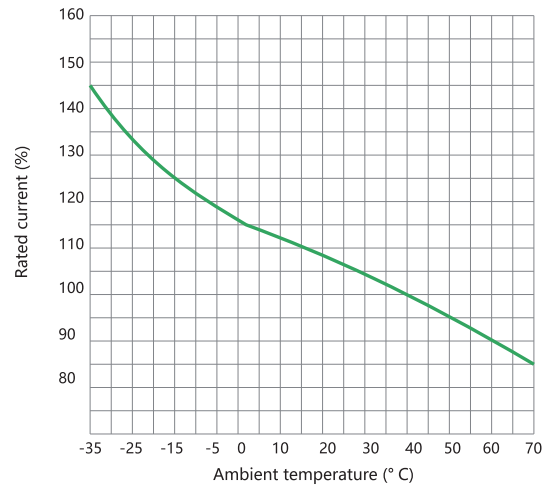

NXM-125, NXMLE-125

Tripping curve

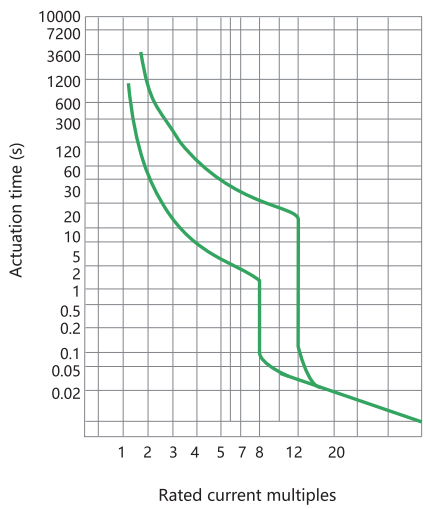

NXM-125, NXMLE-125

Temperature compensation curve

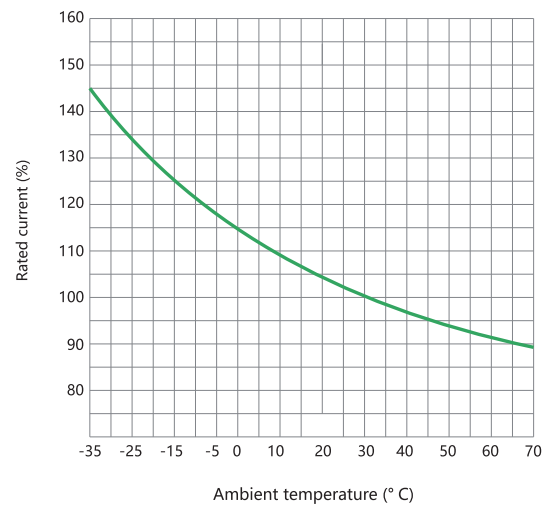



NXM-160, NXMLE-160

Tripping curve

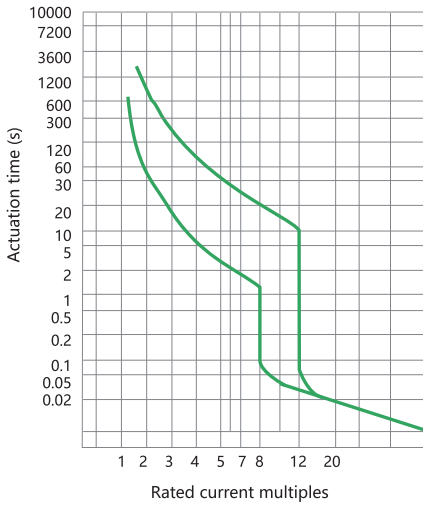

NXM-160, NXMLE-160

Temperature compensation curve

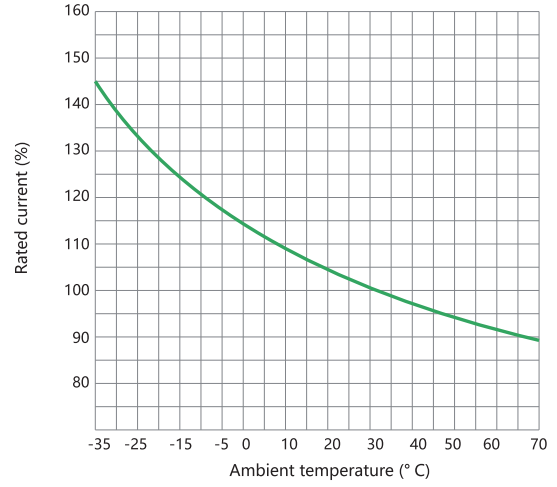

NXM-250, NXMLE-250

Tripping curve

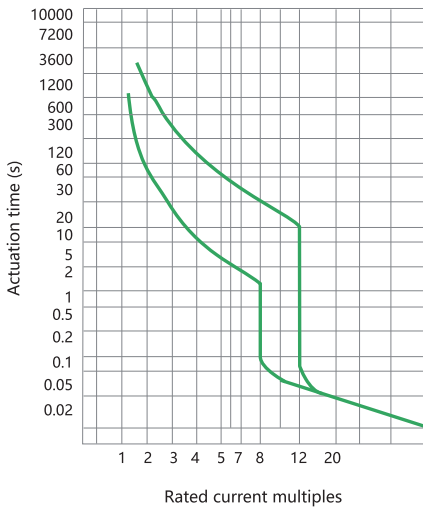

NXM-250, NXMLE-250

Temperature compensation curve

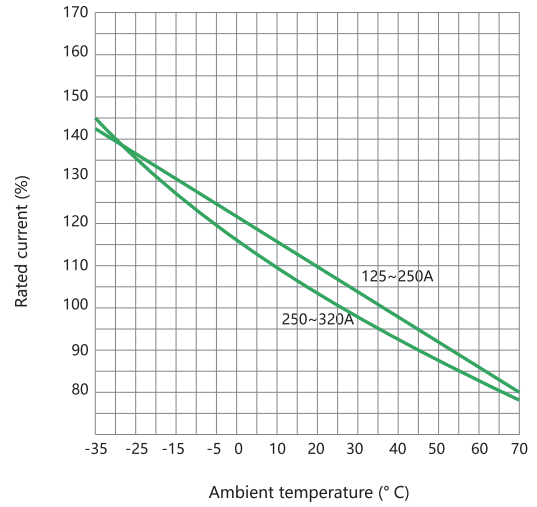

NXM-400/630, NXMLE-400/630

Tripping curve

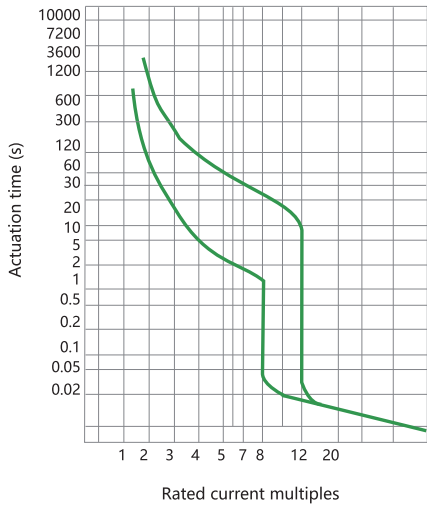

NXM-400/630, NXMLE-400/630

Temperature compensation curve

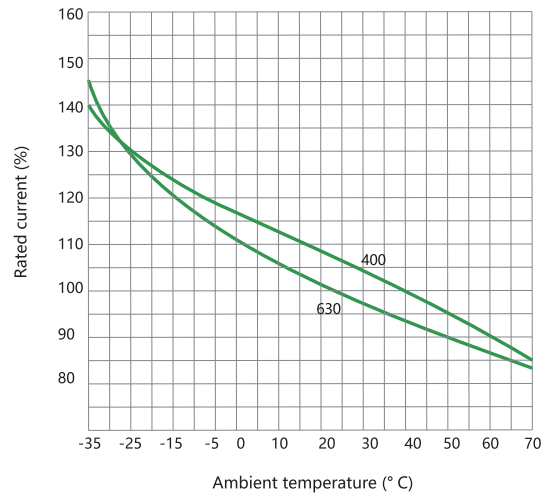

NXM-800

Tripping curve

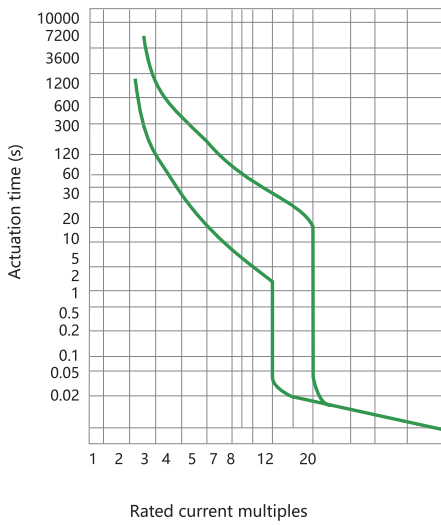

NXM-800

Temperature compensation curve

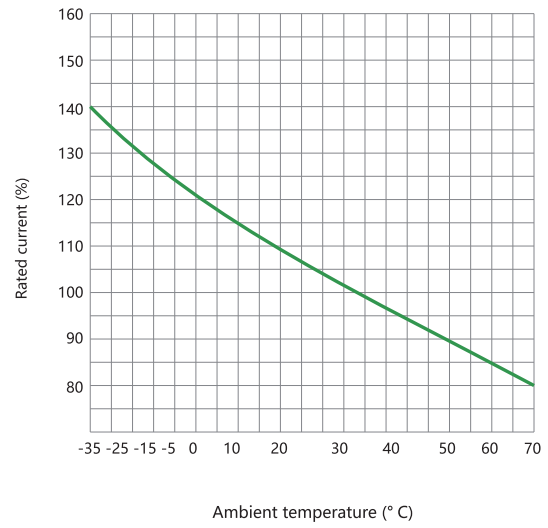



NXM-1000

Tripping curve

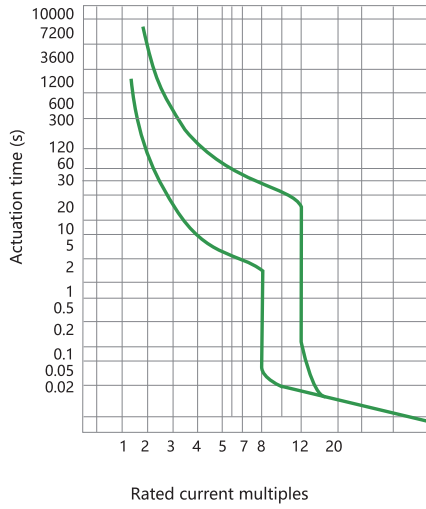

NXM-1000

Temperature compensation curve

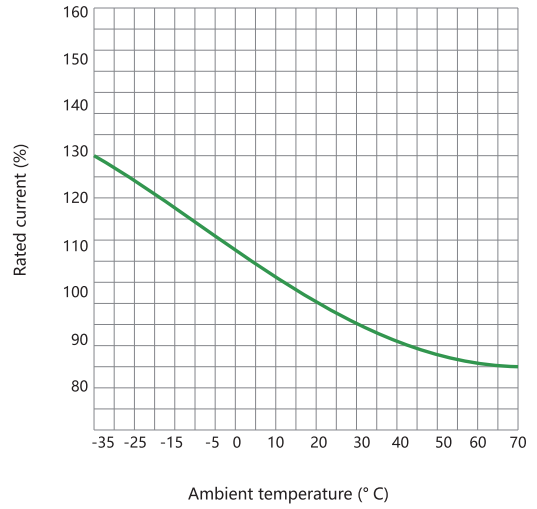

NXM-1250,1600

Tripping curve

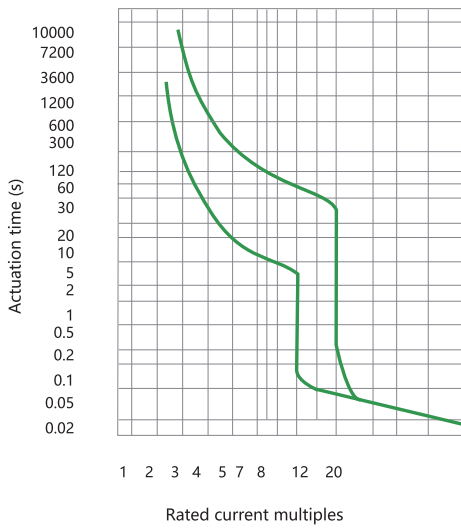

NXM-1250,1600

Temperature compensation curve

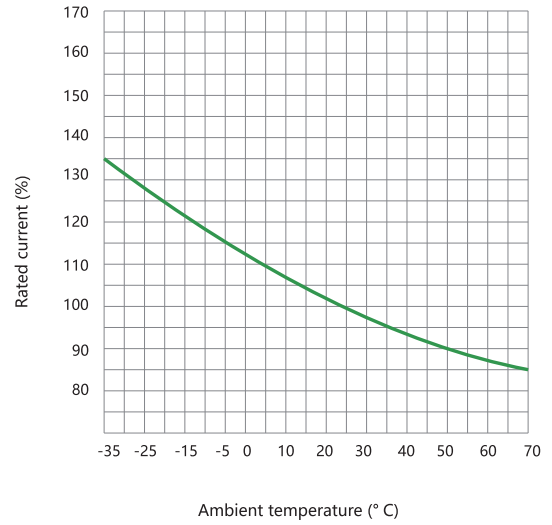

NXMS series electronic moulded case circuit breaker

Tripping curve of distribution protection

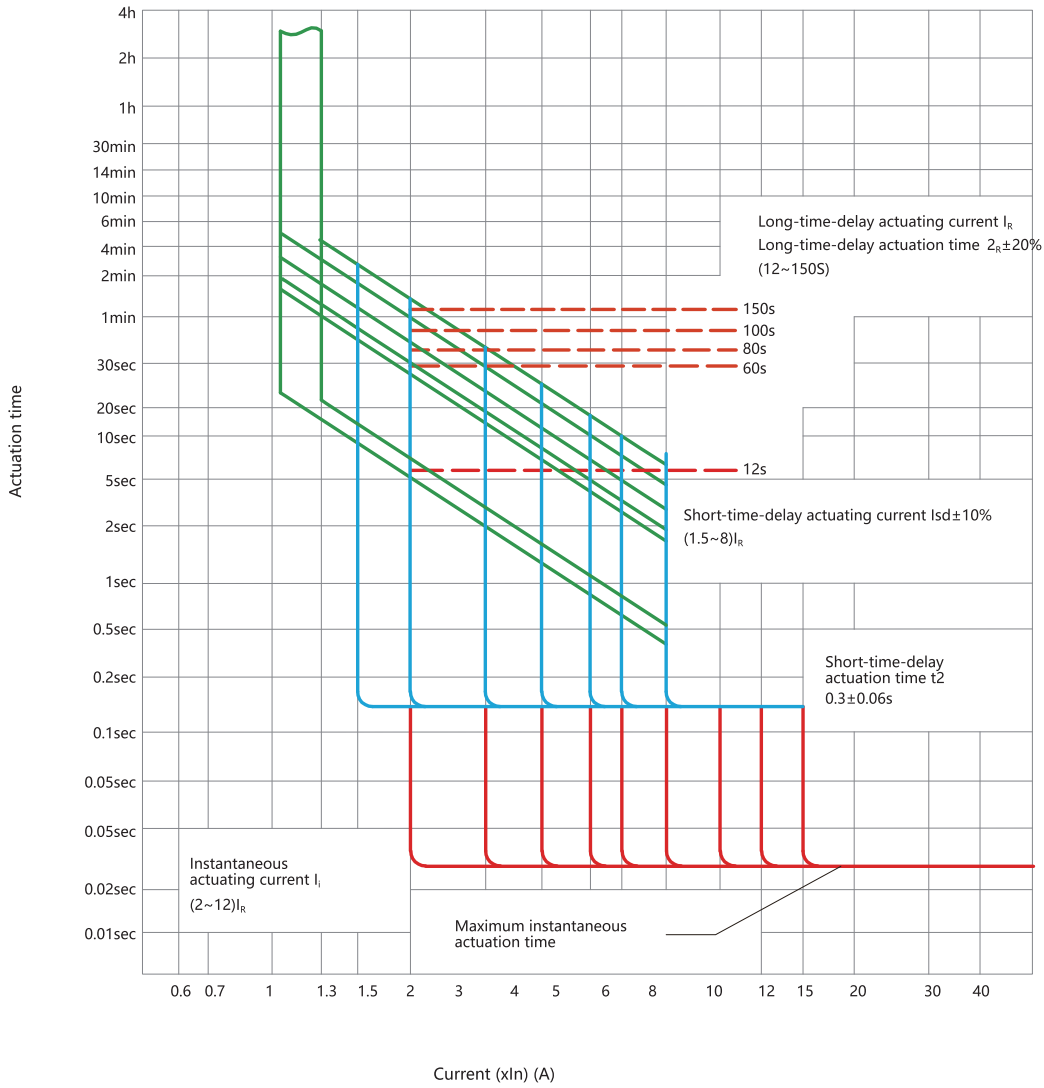

NXMS series electronic moulded case circuit breaker

Tripping curve of motor protection

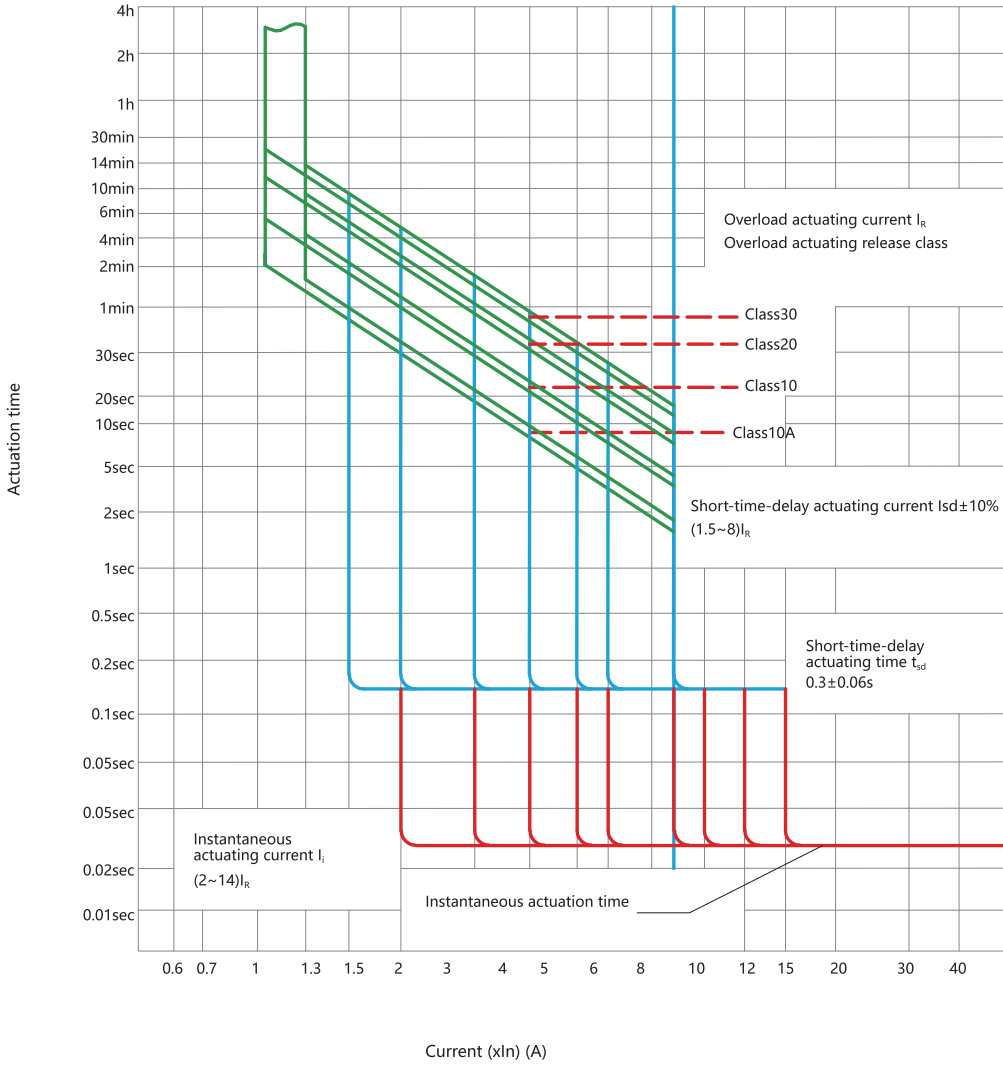

Distributed By:

Choo Chiang Marketing Pte Ltd
 (a subsidiary of Choo Chiang Holdings Ltd)
 did: +65 6368 5922 | fax: +65 6363 5922
 Head Office: 10 Woodlands Loop S(738388)
 website: www.choochiang.com | facebook: facebook.com/choochiang.sg

