

# Ceiling Exhaust Fan

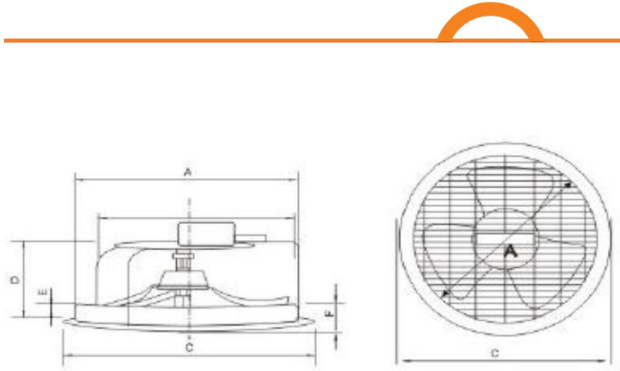

## Parts and installing dimensions

Model	A	B	C	D	E	F
EE200	255	165	305	80	26	46
EE250	297	165	345	80	26	46

## Technical parameter

Model	EE220	EE250
Rating Voltage (v-)	220	220
Rating frequency (Hz)	50	50
Power	25	38
Air Delivery	600	720
Noise	49	55
Dimension (cm)	78.8x32.5x32.7	78.7x37.5x37.4
Carton Qty	6	6
Total Weight(kg)	10.8	13.5

## Stock code

No.	Description
FNE08C.CCM	CCM EE200 200MM CEILING EXHAUST FAN
FNE10C.CCM	CCM EE250 250MM CEILING EXHAUST FAN