



SmartBright Downlight

Trusted performance, everyday

The new Philips SmartBright downlight offers an exceptional value, CCT selector and dimming solution. Available in four sizes to suit a wide variety of standard applications. This is a real professional choose for everyday lighting installations

Features and benefits

- Wide range of lumens - 800/1000/1200/2000lm
- 4 cut out sizes available – D90/D120/D150/D200
- 3 Colour temperatures settings –one device for many applications
- Energy efficient – >105lm/W
- Dimmable – Trailing/leading edge
- IP54 – Suitable for bathroom, under eaves/canopy areas



Applications

- All indoor ceiling installations
- Commercial and retail building environments
- Shopping centers, restaurant, bathroom, etc.



Product highlights

- Tri – color and dimmable
- 30,000hours lifetime/ 2 year warranty
- Pre – wired with plug
- IP54 for the front cover

SmartBright Downlight – DN029B G2

Specifications

	DN029B G2 LED8 D90	DN029B G2 LED10 D120	DN029B G2 LED12 D150	DN029B G2 LED20 D200
Cut out size	D90	D120	D150	D200
Power	7.5W	9W	10.5W	18W
System lumens	800lm	1000lm	1200lm	2000lm
System efficacy	> 105lm/W			
CCT (Selectable)	3000K / 4000K / 6500K			
CRI	>80			
Beam angle	100°			
IP / IK rating	IP54 (front cover) / IK03			
Operating temperature	-20°C < Ta < +40°C			
IC rating	IC – 4			
Input Voltage	220-240V~ 50/60Hz			
Power factor	> 0.8			
Driver	Dimmable			
Lifetime	30,000hours L70B50 @Ta 25°C			
Mounting type.	Recessed ceiling			
Flex & Plug (AU version)	80cm			

Order information

12NC	Description
929002576408	DN029B G2 LED8/CCT PSR-E D90 GM
929002576508	DN029B G2 LED10/CCT PSR-E D120 GM
929002576608	DN029B G2 LED12/CCT PSR-E D150 GM
929002576708	DN029B G2 LED20/CCT PSR-E D200 GM

SmartBright Downlight – DN029B G2

Dimensional Drawings

(units: mm)

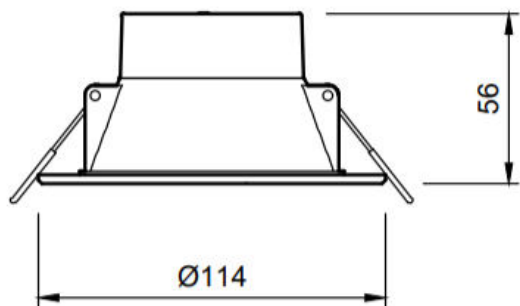

D90 LED8

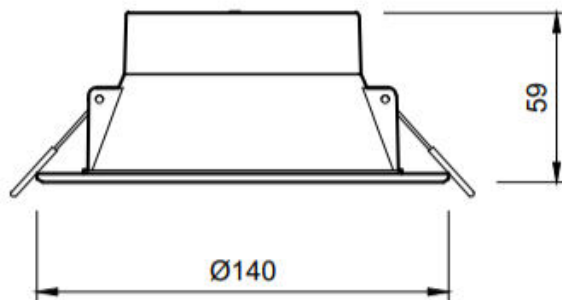

D120 LED10

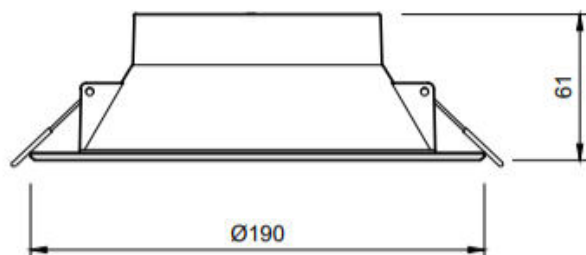

D150 LED12

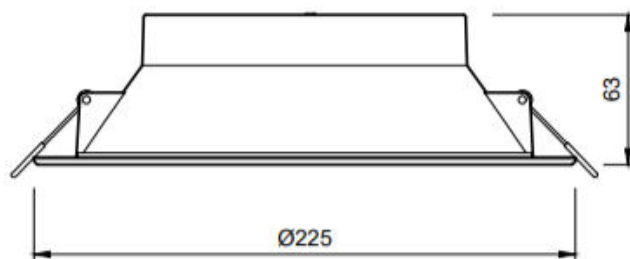

D200 LED20

Product information

12NC	Description	Weights (Kg)	Barcodes
929002576408	DN029B G2 LED8/CCT PSR-E D90 GM	0.23	8719514273566
929002576508	DN029B G2 LED10/CCT PSR-E D120 GM	0.31	8719514273580
929002576608	DN029B G2 LED12/CCT PSR-E D150 GM	0.42	8719514273603
929002576708	DN029B G2 LED20/CCT PSR-E D200 GM	0.58	8719514273627

SmartBright Downlight – DN029B G2

Photometric

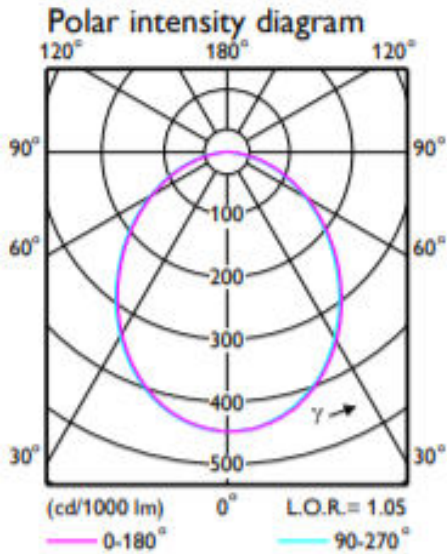

D90 LED8

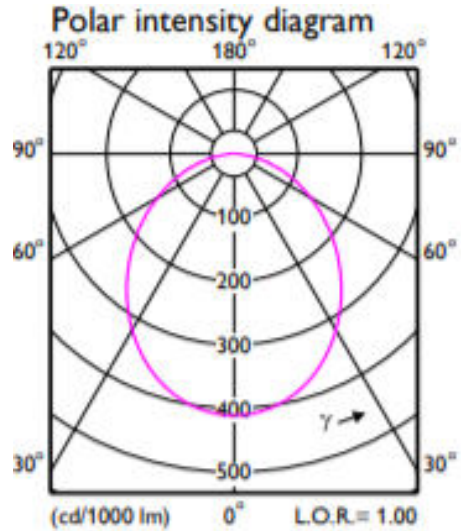

D120 LED10

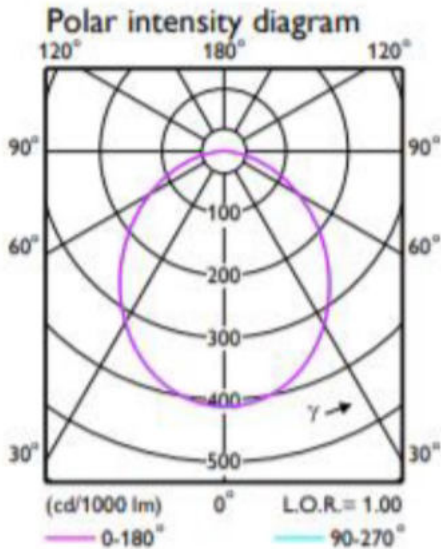

D150 LED12

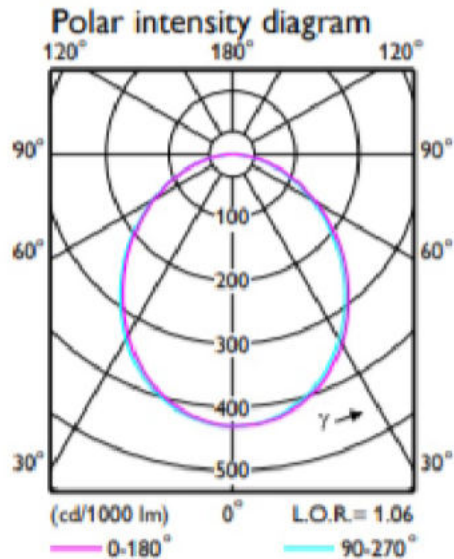

D200 LED20

Distributed By

Choo Chiang Marketing Pte Ltd

(a subsidiary of Choo Chiang Holdings Ltd)

Tel: +65 6368 5922 | fax: +65 6363 5922

Head Office: 10 Woodlands Loop S(738388)

website: www.choochiang.com | facebook: [facebook.com/choochiang.sg](https://www.facebook.com/choochiang.sg)